



Tproof-A lamps

TPA-018/036/050-AH-XXK-ZYYY



Description:

Tproof-A lamps are designed for application sites where waterproof, dustproof and mild corrosion prevention lighting is required such as warehouse, parking lots, foodstuffs factory, dust plant and other sites. The main body and end cover adopts PC materials. With high temperature, the product may be used in application environment with mild corrosion prevention. It is superior to common tri-proof lamps. The optical-electric separation design makes the LED service life reach 60,000 hours.

Features:

1. The rotary end cover facilitates to open for wiring and saves more than half of the installation time.
2. With press type terminals, wiring is performed without use of tools.
3. No buckles, beautiful appearance.
4. High lighting effect, giving out even and soft light. 100LM /W and 130LM /W for selection, 160LM/W for optional.
5. Optional with two ends power in for series connection, max 800W.
6. PC materials for the whole lamp, high impact resistance, IK08.
7. Extrusion design for the lamp body, higher waterproof performance, IP65(emergency series IP40).
8. Use environment temperature: -20°C ~ 40°C(normal series), 0°C ~ 40°C(emergency series).
9. Two installation modes for selection: ceiling holder and suspension rope.
10. Corrosion-proof grade: mild corrosion prevention.



Sensing series introduction

Those tri-proof lamps that built-in sensor can detect moving objects and environment brightness.

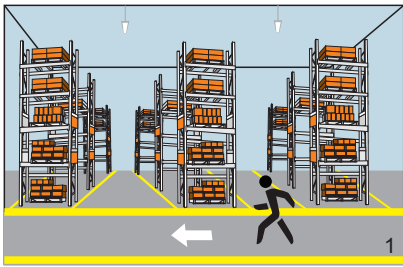

The lamp keeps off in the daytime.



In the evening, if there is moving object around, the lamp switch on.

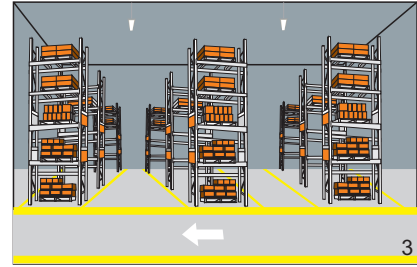

No moving object around, 5 minutes later the lamp switch off.

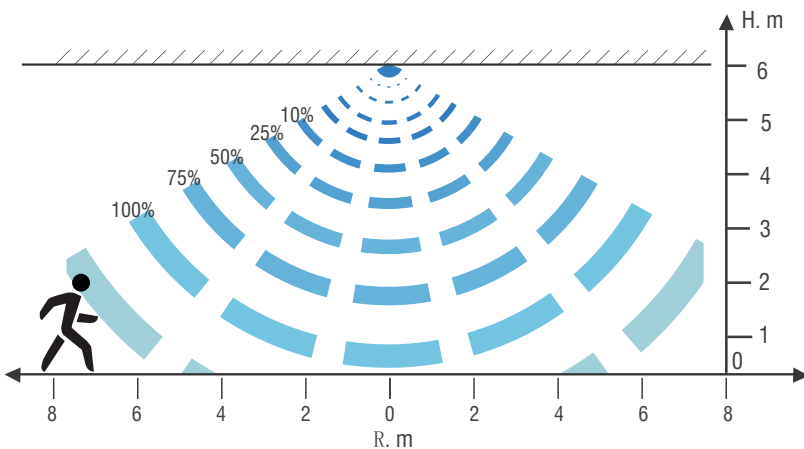

Standby power	<0.5W
Microwave frequency	5.8GHz 75MHz
Microwave power	<1mW
Mounting height	Max.6m
Detection range	Max.14m

Remote controller introduction

All control parameters are set via a remote controller. the remote controller need to be bought separately. Model of remote controller: HD02R

To set the lamp keeps permanently on or off, press "reset" to quit from this mode.

The detection Range will also reduce to sensitivity.

The sensor can be set to only allow the lamp to illuminate below a defined ambient brightness threshold.

*When set to Disable mode, the lamp switch on when motion is detected regardless of ambient light levels.

Refers to the time period the lamp remains at 100% illumination after no motion detected.

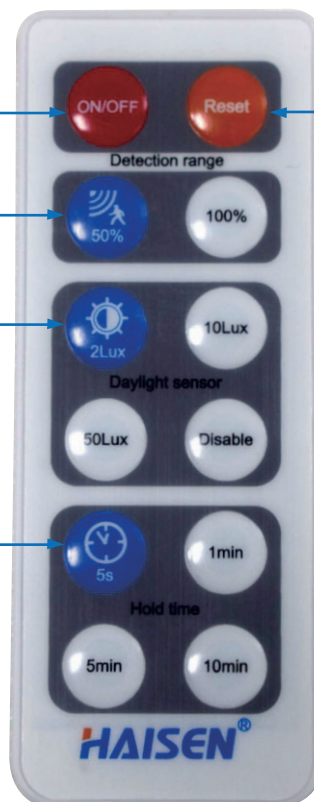

All the setting will be just initial:
Detection range: 100%
Daylight sensor: Disable
Hold time: 5S

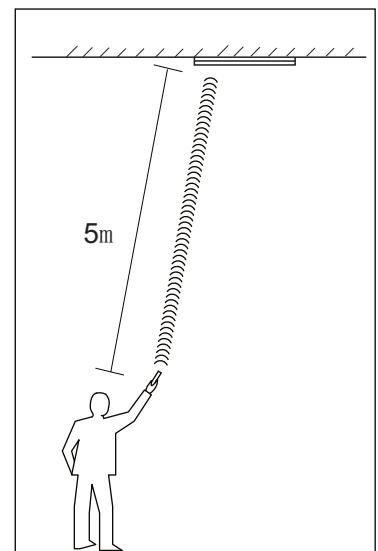



Technical parameters:

Model	CCT	Lumen (lm) (±10%)	Beam angle	LEDs type	Voltage, frequency	Power(w) (±10%)	Max. current (A)	CRI	PF
TPA-018-AH-60K-001/S001/D001	5500-6500K	1800	120°	SMD2835	AC220-240V 50/60Hz	18	0.12	> 80	≥0.9
TPA-018-AH-50K-001/S001/D001	4700-5300K	1800							
TPA-018-AH-40K-001/S001/D001	3800-4200K	1750							
TPA-018-AH-30K-001/S001/D001	2700-3200K	1620							
TPA-036-AH-60K-001/S001/E001/D001	5500-6500K	3600	120°	SMD2835	AC220-240V 50/60Hz	36	0.25	> 80	≥0.9
TPA-036-AH-50K-001/S001/E001/D001	4700-5300K	3600							
TPA-036-AH-40K-001/S001/E001/D001	3800-4200K	3520							
TPA-036-AH-30K-001/S001/E001/D001	2700-3200K	3240							
TPA-050-AH-60K-001/S001/E001/D001	5500-6500K	5000	120°	SMD2835	AC220-240V 50/60Hz	50	0.3	> 80	≥0.9
TPA-050-AH-50K-001/S001/E001/D001	4700-5300K	5000							
TPA-050-AH-40K-001/S001/E001/D001	3800-4200K	4900							
TPA-050-AH-30K-001/S001/E001/D001	2700-3200K	4500							
TPA-018-AH-60K-H01/SH01/DH01	5500-6500K	2340	120°	SMD2835	AC220-240V 50/60Hz	18	0.12	> 80	≥0.9
TPA-018-AH-50K-H01/SH01/DH01	4700-5300K	2340							
TPA-018-AH-40K-H01/SH01/DH01	3800-4200K	2300							
TPA-018-AH-30K-H01/SH01/DH01	2700-3200K	2160							
TPA-036-AH-60K-H01/SH01/EH01/DH01	5500-6500K	4680	120°	SMD2835	AC220-240V 50/60Hz	36	0.25	> 80	≥0.9
TPA-036-AH-50K-H01/SH01/EH01/DH01	4700-5300K	4680							
TPA-036-AH-40K-H01/SH01/EH01/DH01	3800-4200K	4600							
TPA-036-AH-30K-H01/SH01/EH01/DH01	2700-3200K	4320							
TPA-050-AH-60K-H01/SH01/EH01/DH01	5500-6500K	6500	120°	SMD2835	AC220-240V 50/60Hz	50	0.3	> 80	≥0.9
TPA-050-AH-50K-H01/SH01/EH01/DH01	4700-5300K	6500							
TPA-050-AH-40K-H01/SH01/EH01/DH01	3800-4200K	6400							
TPA-050-AH-30K-H01/SH01/EH01/DH01	2700-3200K	6000							

001/S001/E001/D001=Milky lamp shade series/Sensor series/Emergency series/DALI dimming series

H01/SH01/EH01/DH01=High output series/Sensor series/Emergency series/DALI dimming series



Dimensions(Unit:mm/inch):

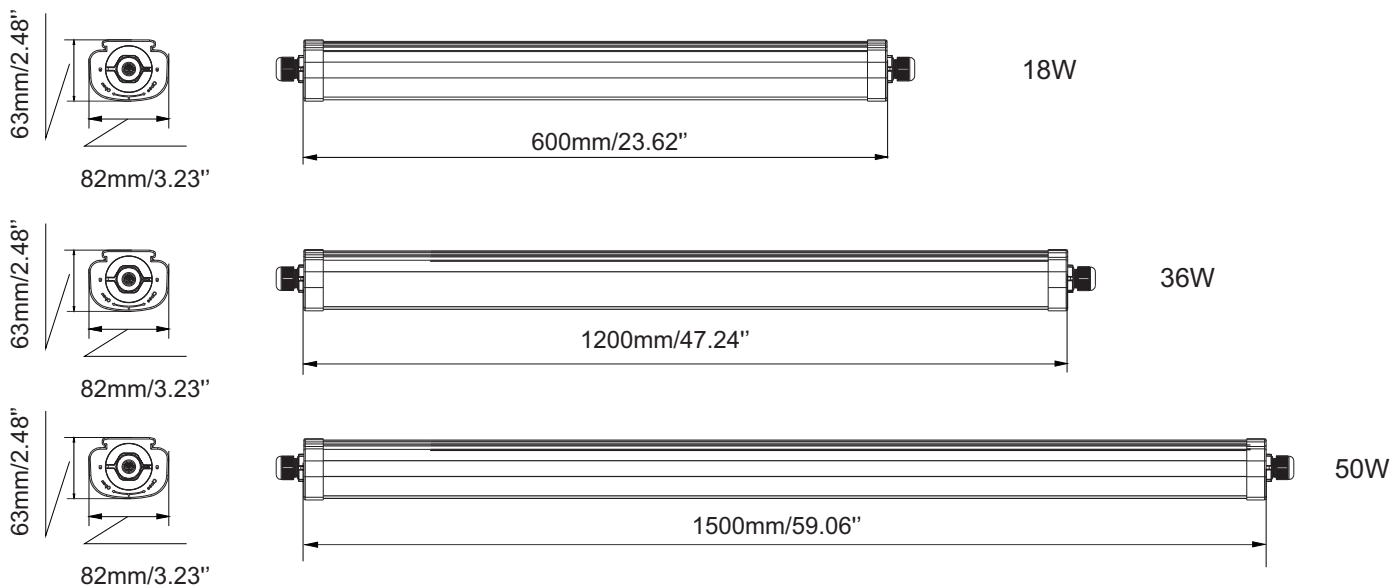

Installation drawings:

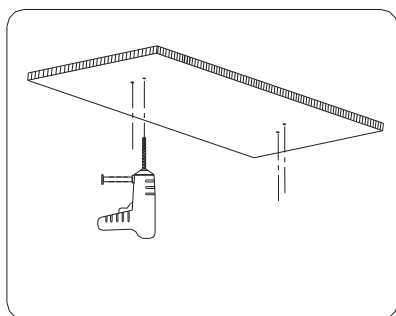

1. Drill hole size of ceiling installation.

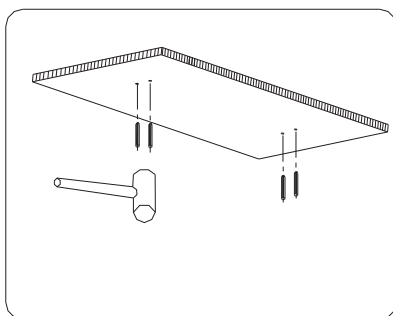

2. Hammer the Anchor into the hole.

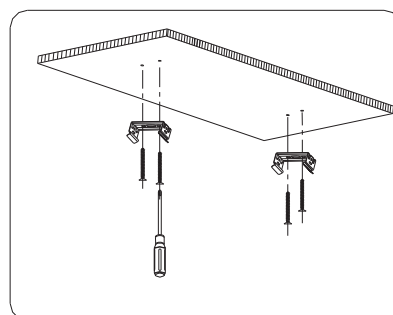

3. Install the Self-tapping screws into the Anchor and fix it by a philips screwdriver.

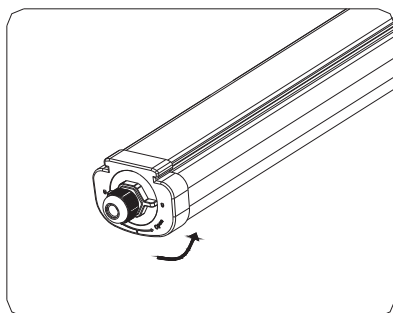

4. Turn the lamp holder counterclockwise.

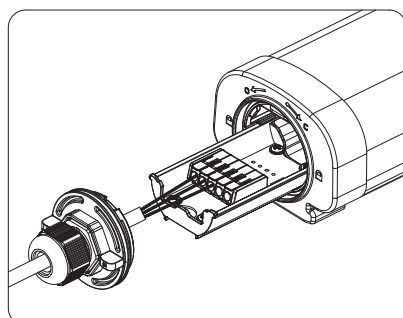

5. Connect the AC cable to the terminal through M20 waterproof connector, and then plug the terminal into the end cap.

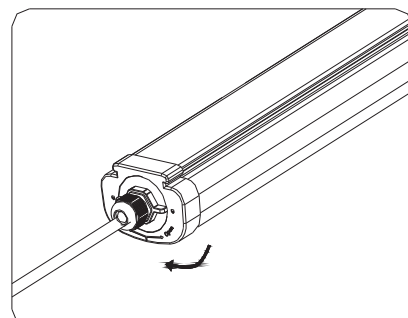

6. Turn the lamp holder clockwise and tighten it.

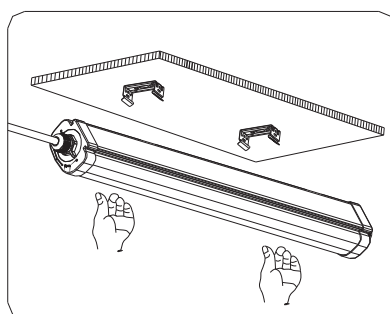

7. Clip the lamp onto a fixed bracket on the ceiling.



Ceiling installation A

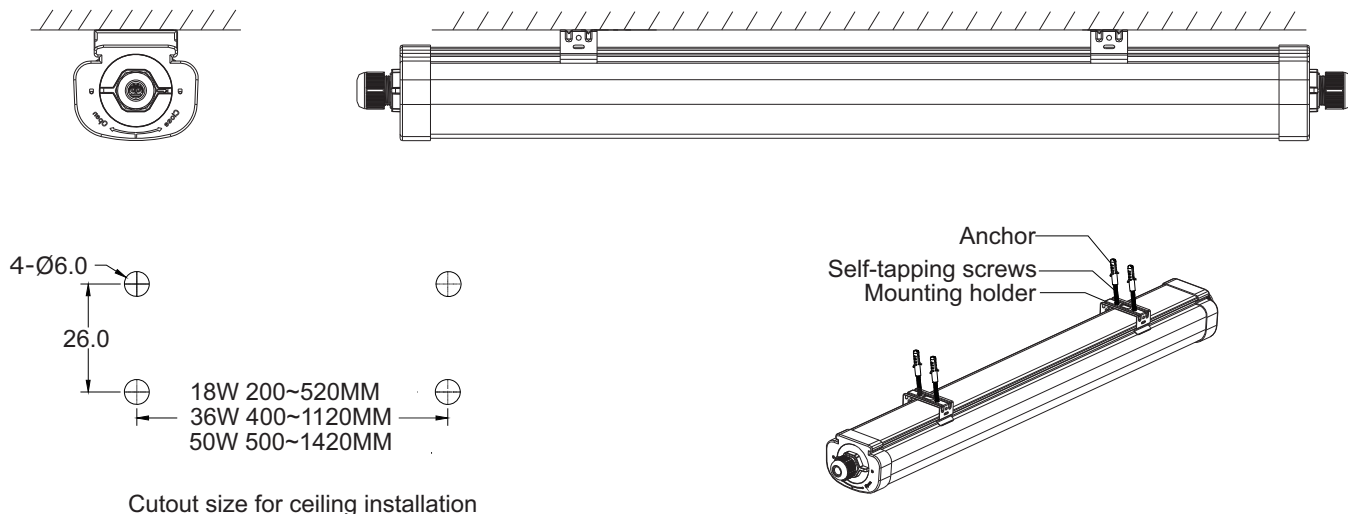

Ceiling installation B

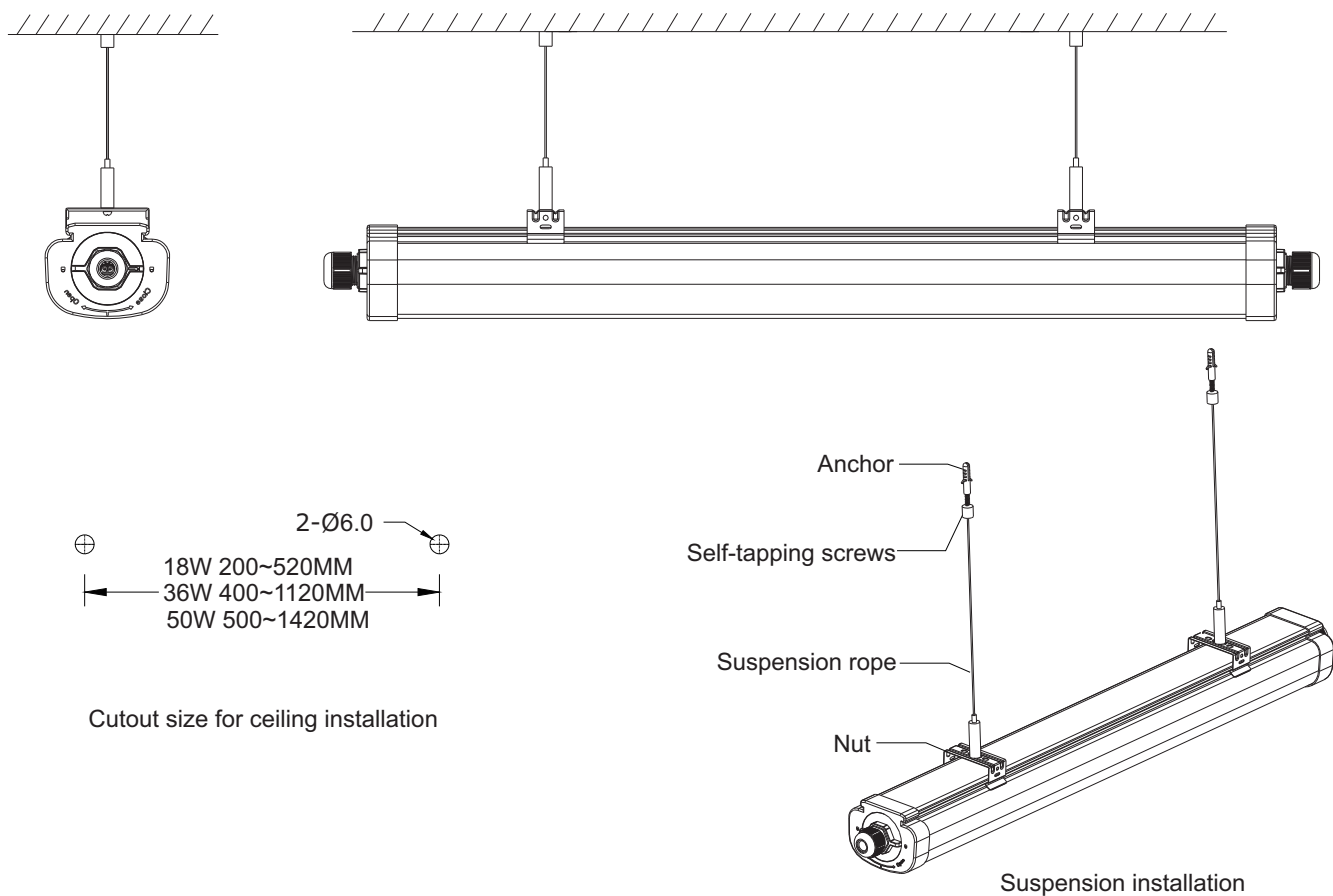

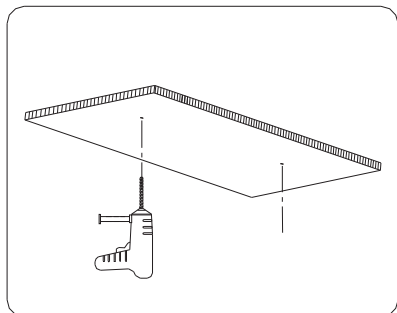

1. Drill hole size of ceiling installation.

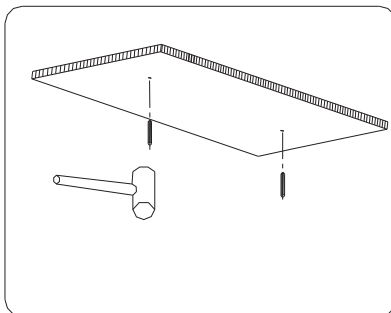

2. Hammer the Anchor into the hole.

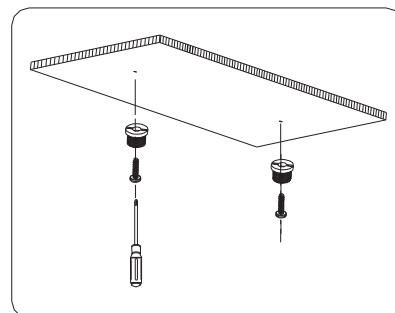

3. Install the Self-tapping screws into the hollow nut and fix it to the Anchor on the ceiling.

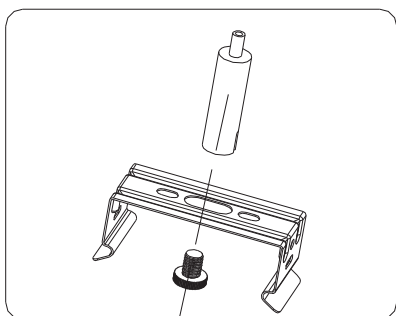

4. Screw the nut on the retainer through the ceiling bracket.

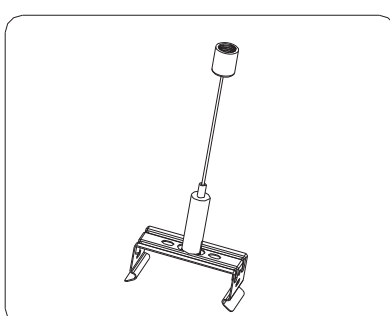

5. Pass the suspension sling through the retaining sleeve, tighten it on the hollow nut, and then pass the other end through the retainer.

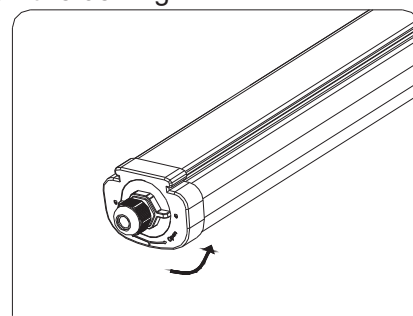

6. Turn the lamp holder counterclockwise.

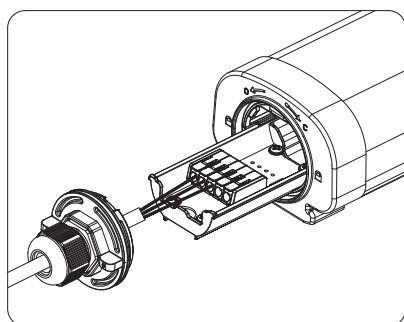

7. Connect the AC cable to the terminal through M20 waterproof connector, and then plug the terminal into the end cap.

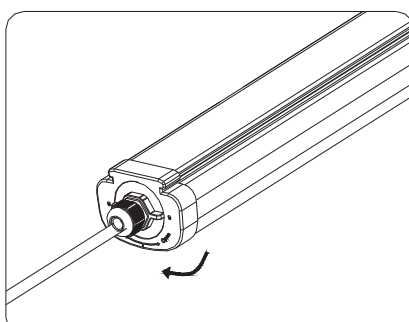

8. Turn the lamp holder clockwise and tighten it.

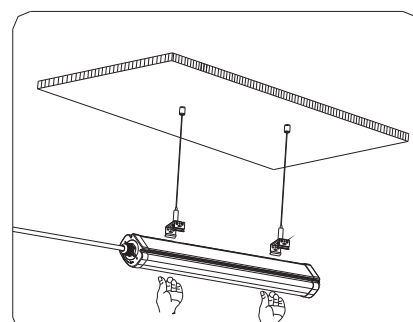

9. Fix the lamp into the clip of suspension rope.

Product packaging information:

Size	Inner packing size	Carton size	Net weight	Gross weight	Quantity
0.6M	18W: 645*95*70mm	18W: 660*300*230mm	0.60Kg	0.90Kg	9pcs/Carton
1.2M	36W: 1245*95*70mm	36W: 1260*300*230mm	1.00Kg	1.50Kg	9pcs/Carton
1.5M	50W : 1545*95*70mm	50W: 1560*300*230mm	1.30Kg	1.90kg	9pcs/Carton



Application:

Tproof-A lamps may be used in warehouse, parking lot, foodstuffs factory, dust plant and refrigeratory and other sites.



Installation requirement:

1. Please read the instructions carefully before installation.
2. Power off before installation.
3. Thread the input cable through the waterproof joint, and then connect the input wire end with the terminal to ensure reliable contact.
4. Tighten the rotary knob holder.
5. Choose ceiling installation, fix ceiling bracket on the installation surface via self-tapping screws and flat gasket, then snap the lamp body into bracket.
6. If you choose suspension installation, please first fix the steel wire on the installation surface, and fix the wirelock on bracket with nut, then snap the lamp body into bracket, finally adjust the length of steel wire.
7. CCT tunable lamps: through DIP switch to realize the adjustment between 3 kinds of CCT.

! Notice

1. Please first read the product specification carefully, make sure the using environment conform to specification, then it can be used.
2. Please confirm input voltage, frequency before use.
3. The lamp must be installed by professionals.
4. If there is any damage to the power wire or shell of the product, it should be taken as defective product and do not use it.
5. Dangerous high voltage, non-professionals are not allowed to maintain the product.
6. If external soft cable or soft wire of the light is damaged, it should be replaced by manufacturer or service agent or personnel with similar qualification to avoid danger.
7. When connect wire of AC, the terminal shouldn't press to external skin, ensure good contact.
8. Please do not let water enter the internal, please do not knock against the LEDs' surface.
9. Corrosivity in the using environment can't exceed the anti-corrosion grade regulation, if you have special requirement, please first consult with our company.
10. Working environment temperature of products with emergency function: 0°C ~ 40°C.
11. Side Installation on wall surface is not allowed.
12. Outdoor site application is prohibited.