

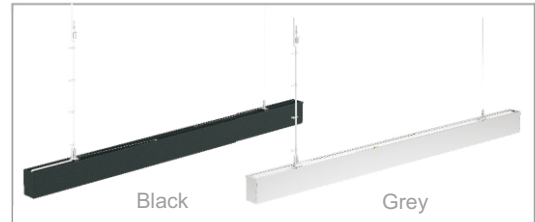

LED Linear Light

SL 8050 in continuous run



Black

Grey



Description

LED linear light is exclusively designed for designer and architect with imagination and personal style. LED linear light adopt premium aluminum profile, different dimension and size, easy to install. 3 types installation method: ceiling mounted type, suspended type and embedded type, and different customized dimensions are also acceptable, which can meet installation requirement of different fields and occasions.

Features

1. Simple and modern design, screwless at end cap.



2. Extrusion aluminum lamp body and PC cover.

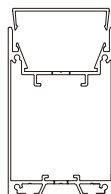

3. Smooth and soft lighting effect, no dark dot and shadow at the lighting_area.





4. Various installation: Suspended, ceiling and recessed.

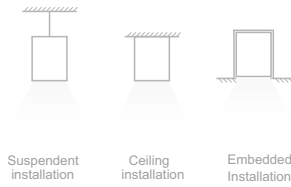

5. Three colors of lamp body, white, black and silver.



6. Continuous connection at max 550W run.

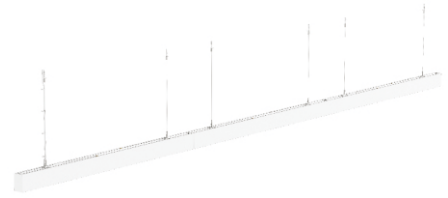

Specifications



First run

Model	CCT	LED Type	Lumen(lm) (±10%)	Power(W) (±10%)	Length(mm)	Voltage (V)
SC-SL8050-018-AW-02W	6000-6500K	2835	1656lm	18W	600	AC 100-240V 50/60Hz
SC-SL8050-018-AW-02NW	3800-4200K		1620lm	18W	600	
SC-SL8050-018-AW-02WW	2800-3200K		1530lm	18W	600	
SC-SL8050-036-AW-02W	6000-6500K	2835	3312lm	36W	1200	AC 100-240V 50/60Hz
SC-SL8050-036-AW-02NW	3800-4200K		3240lm	36W	1200	
SC-SL8050-036-AW-02WW	2800-3200K		3060lm	36W	1200	
SC-SL8050-045-AW-02W	6000-6500K	2835	4140lm	45W	1500	AC 100-240V 50/60Hz
SC-SL8050-045-AW-02NW	3800-4200K		4050lm	45W	1500	
SC-SL8050-045-AW-02WW	2800-3200K		3825lm	45W	1500	

Middle run

Model	CCT	LED Type	Lumen(lm) (±10%)	Power(W) (±10%)	Length(mm)	Voltage (V)
SC-SL8050-018-AW-03W	6000-6500K	2835	1656lm	18W	600	AC 100-240V 50/60Hz
SC-SL8050-018-AW-03NW	3800-4200K		1620lm	18W	600	
SC-SL8050-018-AW-03WW	2800-3200K		1530lm	18W	600	
SC-SL8050-036-AW-03W	6000-6500K	2835	3312lm	36W	1200	AC 100-240V 50/60Hz
SC-SL8050-036-AW-03NW	3800-4200K		3240lm	36W	1200	
SC-SL8050-036-AW-03WW	2800-3200K		3060lm	36W	1200	
SC-SL8050-045-AW-03W	6000-6500K	2835	4140lm	45W	1500	AC 100-240V 50/60Hz
SC-SL8050-045-AW-03NW	3800-4200K		4050lm	45W	1500	
SC-SL8050-045-AW-03WW	2800-3200K		3825lm	45W	1500	



Last run

Model	CCT	LED Type	Lumen(lm) (±10%)	Power(W) (±10%)	Length(mm)	Voltage (V)
SC-SL8050-018-AW-04W	6000-6500K	2835	1656lm	18W	600	AC 100-240V 50/60Hz
SC-SL8050-018-AW-04NW	3800-4200K		1620lm	18W	600	
SC-SL8050-018-AW-04WW	2800-3200K		1530lm	18W	600	
SC-SL8050-036-AW-04W	6000-6500K	2835	3312lm	36W	1200	AC 100-240V 50/60Hz
SC-SL8050-036-AW-04NW	3800-4200K		3240lm	36W	1200	
SC-SL8050-036-AW-04WW	2800-3200K		3060lm	36W	1200	
SC-SL8050-045-AW-04W	6000-6500K	2835	4140lm	45W	1500	AC 100-240V 50/60Hz
SC-SL8050-045-AW-04NW	3800-4200K		4050lm	45W	1500	
SC-SL8050-045-AW-04WW	2800-3200K		3825lm	45W	1500	
Beam angle		PF	CRI	IP	Life span	Reflector
110°		> 0.95	≥80	IP40	50000hrs	Milky cover

Applications

Suitable for hotels,conference rooms, factories,offices,commercial purposes, institution buildings,schools,colleges, universities,hospitals and other places which needs energy saving and high color rendering index lighting.



Dimensions (Unit: mm/inch)

First run

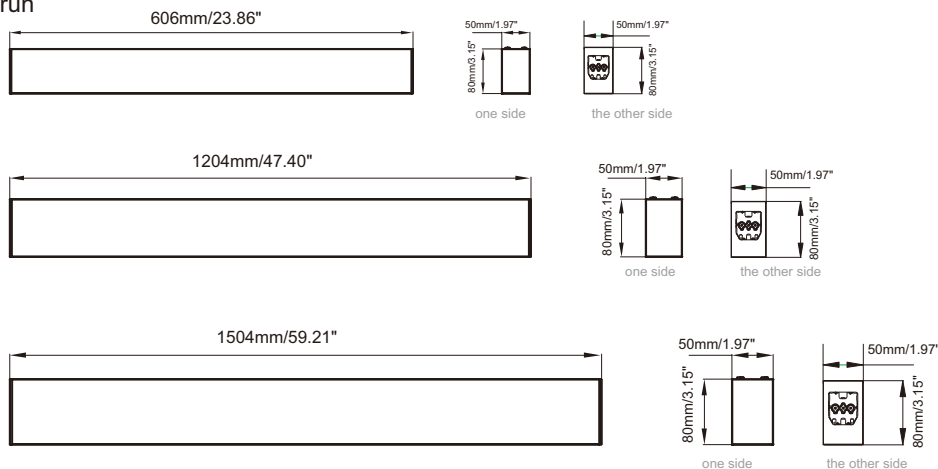



Middle run

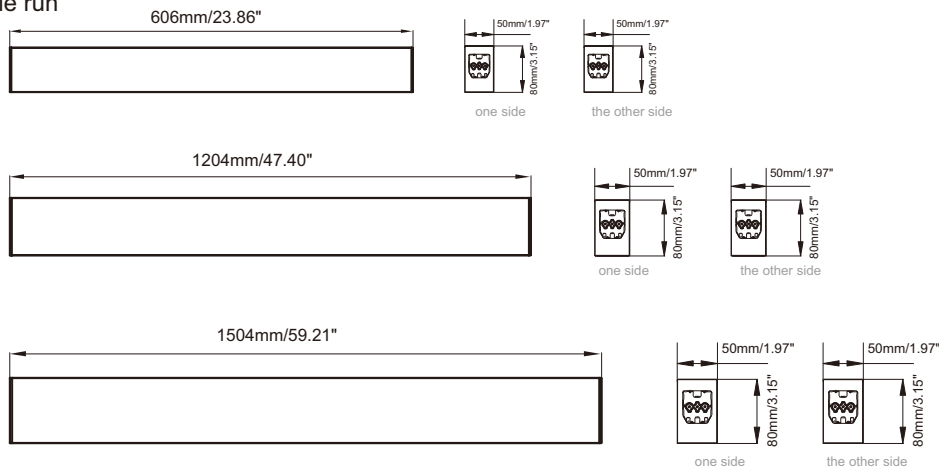

Last run

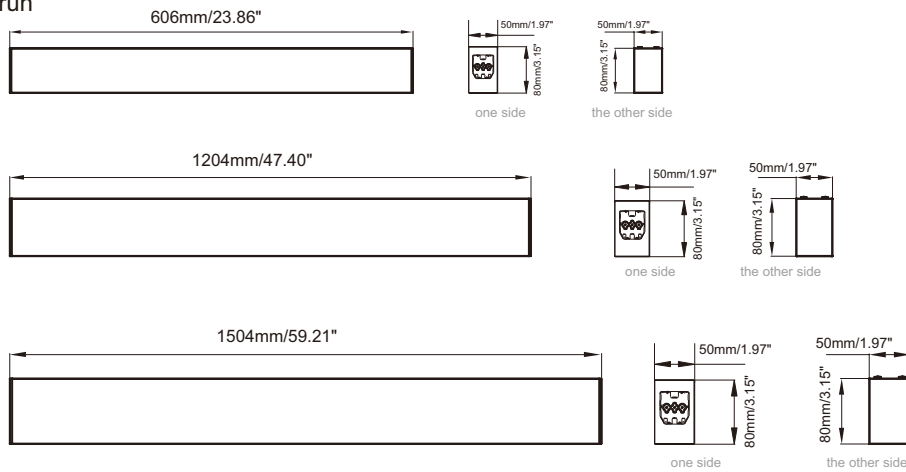

Electrical Connection

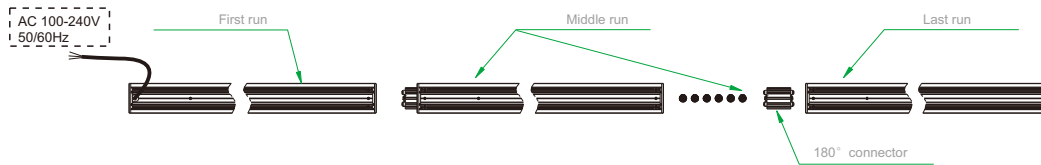

When input voltage is AC110V, the max continuous connection run is 250W
 When input voltage is AC220V, the max continuous connection run is 550W.



How to connect

a. 8050 first run 1PC	b. 3.5*15PA screw (N-1)*12PCS	c. 180° connector (N-1) pcs	d. 8050 middle run (N-2)pcs	e. 8050 last run 1PC
-----------------------	-------------------------------	-----------------------------	-----------------------------	----------------------

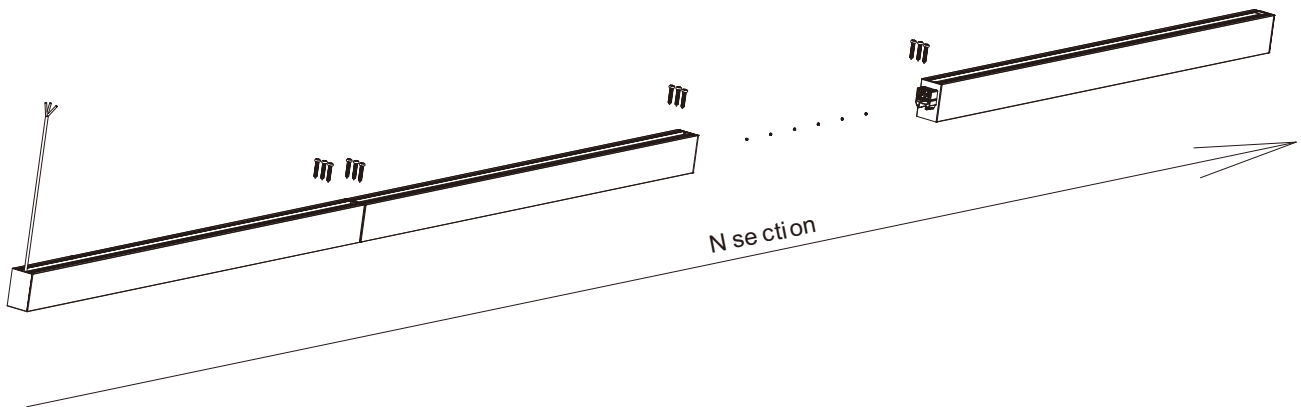
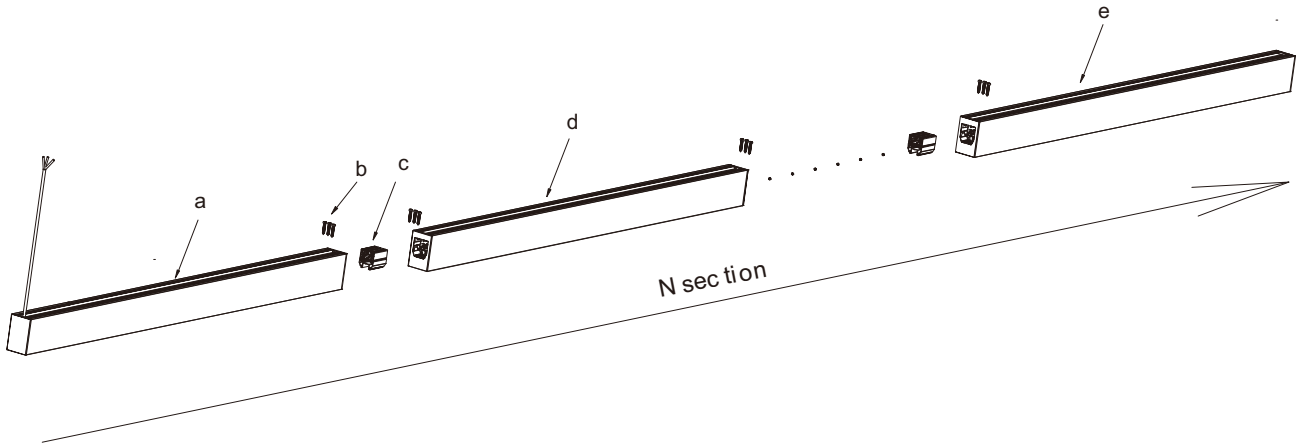

step1: Insert two ends of 180° connector into cavity of side cover, and fix joint part with 3.5X15PA screw and 180° connector; connect the first run, wire to the power supply.

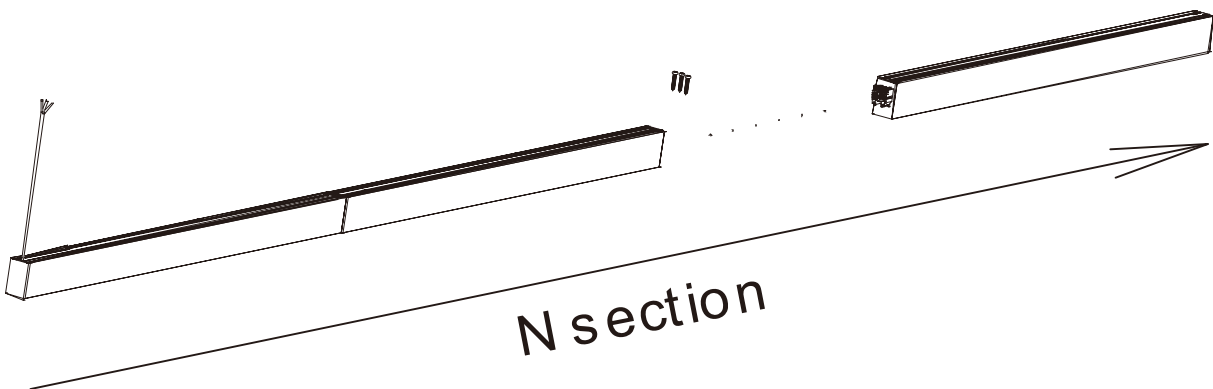

Step2: Installation finish.



How to install

Suspendent installation

Step1:Accessories

1. lamp body	1pcs	2. square-head screw	4pcs	3. safety rope	2pcs	4. fixing head 3	4pcs
5. sewing machine	2pcs	6. suspendent rope	2pcs	7. fixing head 1	2pcs	8. 4X30PA screw	2pcs
9. fixing head 2	2pcs	10. rubber plug	2pcs	11. fixing head 3	4pcs	12. doubling clamp	4pcs
13. screw	2pcs						

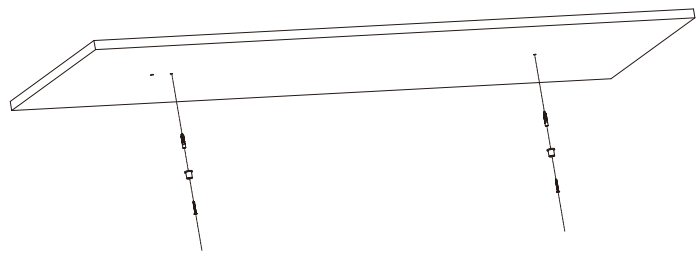
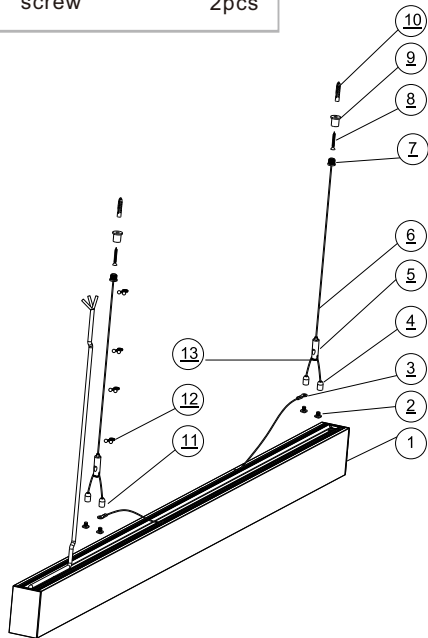

Step2:Drill hole in the ceiling, push the rubber plug into the ceiling, fix the fixing head 2 in the ceiling with 4X30PA screw.

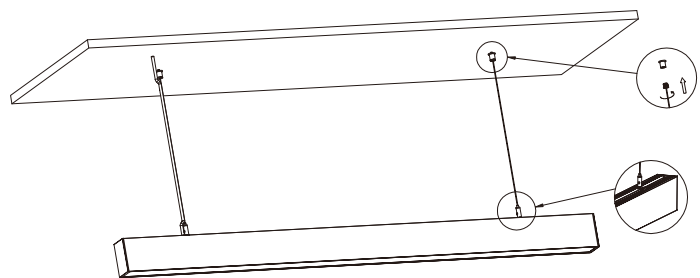
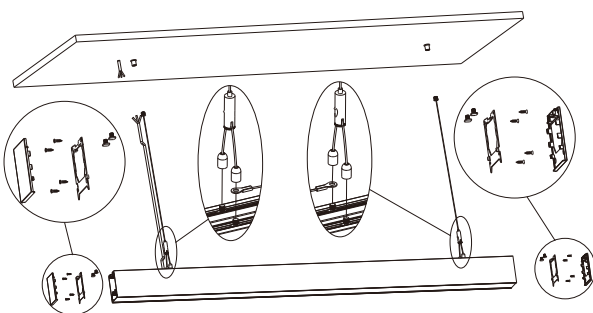

Step3:1. Dismantle the end cap, screws and fixing pieces of end cap on both ends of the lamp, then slide the square-head screw into the card slot of lamp, finally assemble the end cap, screws and fixing pieces of end cap back. If the square-head screw is already slid into the card slot of lamp, you can skip this step.
2. As shown on the diagram, put the safety rope onto the square-head screw, then tighten the fixing head 3 and square-head screw onto the lamp.

Step4:a. Suspendent method on the left: thread the power wire through 8-figure buckle fixed on the left, then intall the whole set of fixing clip on the lamp;

Step5:fix the fixing head 1 with fixing head 2 tightly, and adjust suspendent rope with sewing machine to balance the lamp, finally connect input wire of lamp;

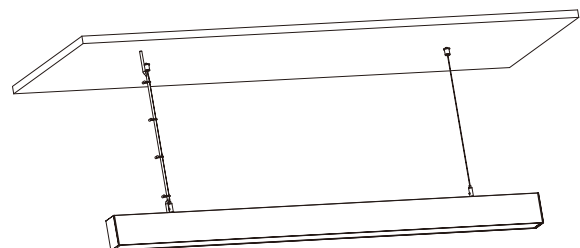

Step5



Ceiling installation

Step1:Accessories

a.	8050 lamp	1pcs	b.	4*25PM screw	2pcs	c.	clip	2pcs	d.	rubber plug	2pcs
----	-----------	------	----	--------------	------	----	------	------	----	-------------	------

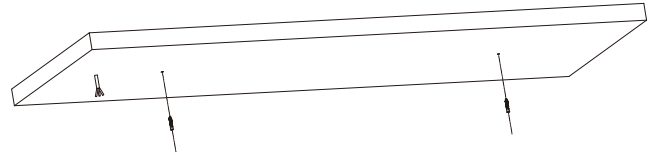
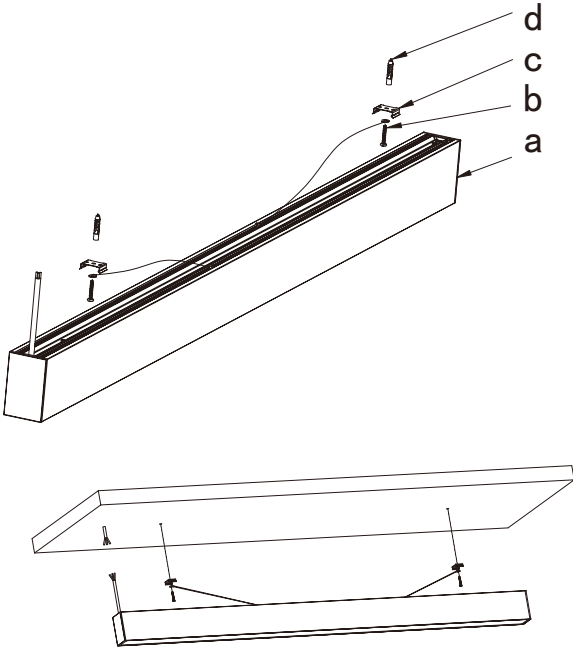

Step2:Drill hole in the ceiling, and push rubber plug into the hole.

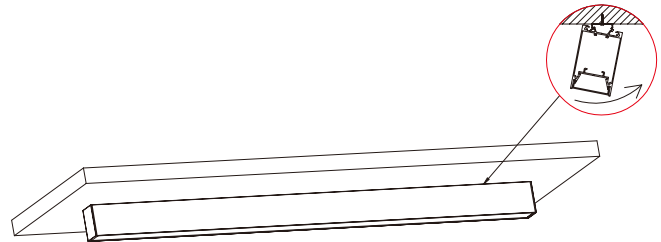

Step3:Thread 4X25PA screw through fixing hole of safety rope and clip, finally fix 4X25PA screw and rubber plug tightly.

Step4:Connect input wire of lamp and install the lamp on the clip.

Embedded Installation

Step1:Accessories

a.	8050 lamp	1pcs	b.	4*70PM screw	2pcs	c.	gasket	4pcs	d.	clip	2pcs
e.	3*20PA screw	4pcs	f.	spring	2pcs	g.	embedded bracket	2pcs	h.	M4 nut	4pcs

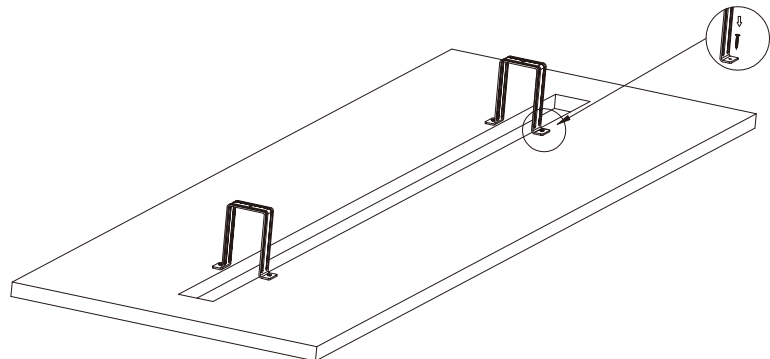
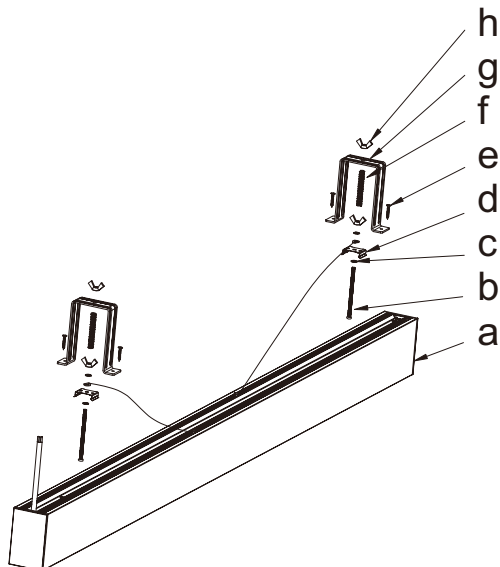

Step2:Slot in the ceiling, the slot dimension is L1205*W51mm, and fix the embedding bracket with3X20PA screws.

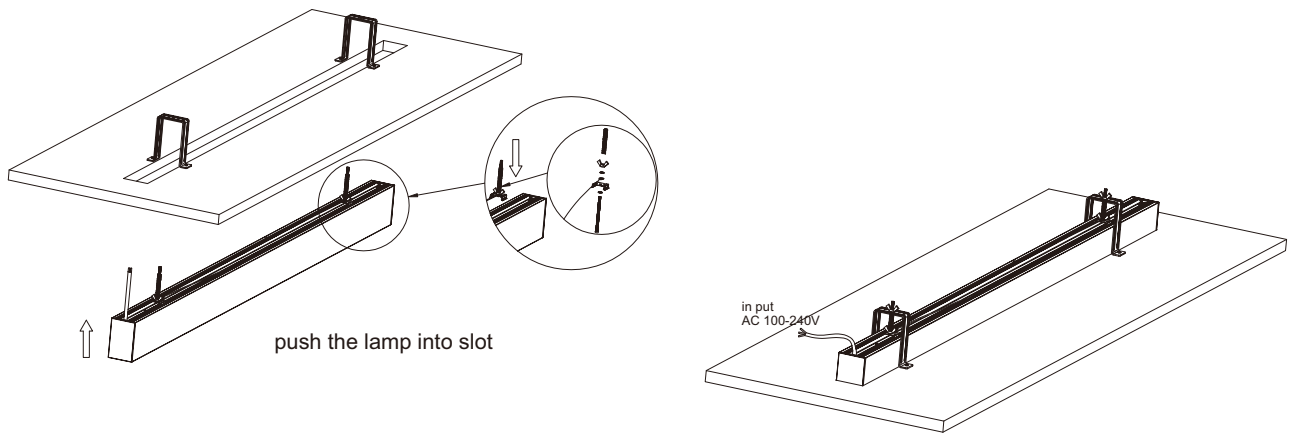

Step3. Install and fix gasket, clip, safety rope according order in above figure with 4X70PM screws and M4 nut; install the spring on 4X70PM screw, then snap the whole set of fixing clips into lamp, finally push the lamp into slot.

Step4: Fix lamp with M4 nut and 4X70PM screw, and adjust the M4 nut to align the lamp luminous face of lamp with ceiling, finally connect lamp with input wire.

Product packaging information:

18W	36W	45W
<ul style="list-style-type: none"> ● Net weight/PC: 1.22kg ● Embedded gross weight/CTN: 22.6kg ● Ceiling gross weight/CTN: 19.7kg ● Suspended gross weight/CTN: 20.7kg ● Inner size: 676X130X106mm ● Carton size: 690X534X336mm ● 1pcs/inner box, 12 inner boxes/carton. 	<ul style="list-style-type: none"> ● Net weight/PC: 2.21kg ● Embedded gross weight/CTN: 19.2kg ● Ceiling gross weight/CTN: 17.8kg ● Suspended gross weight/CTN: 18.3kg ● Inner size: 1274X130X106mm ● Carton size: 1288X404X230mm ● 1pcs/inner box, 6 inner boxes/carton 	<ul style="list-style-type: none"> ● Net weight/PC: 2.58kg ● Embedded gross weight/CTN: 23kg ● Ceiling gross weight/CTN: 21.5kg ● Suspended gross weight/CTN: 22kg ● Inner size: 1552X130X110mm ● Carton size: 1566X404X238mm ● 1pcs/inner box, 6 inner boxes/carton

! Notice

1. The max current consumption of our driver to 0-10V dimmer is 2 mA each one
2. Please read the specification first, to make sure the service environment matches the condition in the specification before using.
3. Please confirm the applicable power supply before using.
4. Make sure the switch of product is off before connect to the power supply to prevent electric shock.
5. Operation against rules may damage your property even harm to your personal safety.
6. Preliminarily estimate required quantity of LED linear lights, then according to the power rating of single linear light to figure out the total power and design power supply plan.
7. Dangerous high voltage, Non-professionals are not allowed to maintain the products.
8. If the exterior flexible cable or wire is damaged, it must exchange by the supplier, its agent or other similar qualified personnels to avoid dangers.