



# MOSQUITO-REPELLING & AMBIENCE LIGHTING

LED STRIP LIGHT



SC-(2835+5050)-TT1515W-(WW+RGB)-5-120-10-IP67



Mosquito repellent effect

## Mosquito repellent & ambient lighting

A silicone sleeved LED strip that emits two types of light, up and down light, left and right light, and emits different lights simultaneously in two directions

Ambient lighting

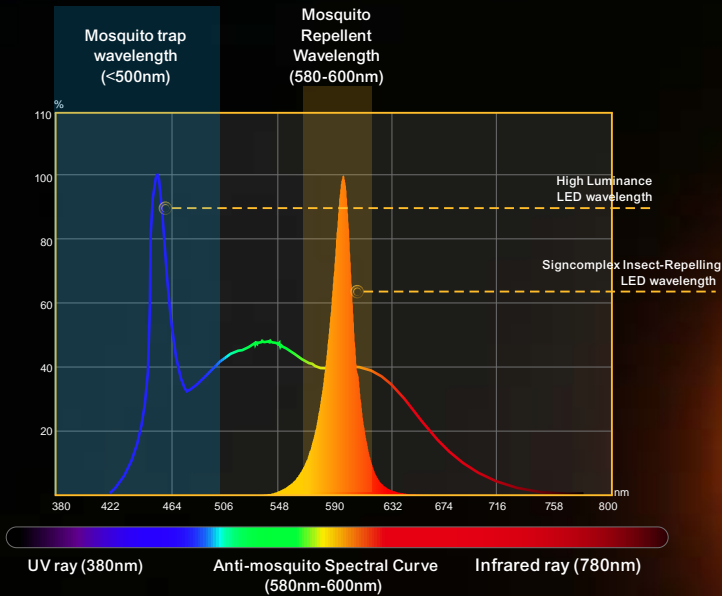

# RGB & **MAGIC EFFECTS**

SMD5050 external IC LED, multiple color variations, static and dynamic ambient lighting effects.

## Effective mosquito repellent

It uses a special light source to attract mosquitoes and effectively repel them.



## Physical mosquito repellent

Meets the customer's need for mosquito prevention during outdoor travel and camping, energy-saving and environmentally friendly, with no side effects.

## PORTABLE & EASY TO USE

Small in size and easy to carry. It can be placed on camping tables or at tent entrances for convenience.

## IP67 WATERPROOF



Suitable for outdoor use and can be used without worry even in the rain.



## PARAMETER

Model	Wave Length & CCT Range (for LED only)		LED Type	LED Qty. (PCS/M)	Rated Watt (w/m)	DC Voltage (V)	Max. Length (M)	Min. Length (mm)	PCB Width	IP	Beam angle (degree)
SC-(2835+5050)- TT1515W- (WW+RGB) -5-120-10-IP67	WW	590nm	2835	120	5	5	5	8.33	10	67	2*110
	R	620-630nm									
	G	515-530nm									
	B	460-470nm	5050	60				50			

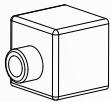
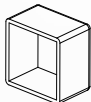
## ACCESSORIES

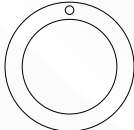
Item	Endcap with hole	Endcap without hole	Suspension hook	Collar loop
Picture				
Qty.	2pcs/ 5M	2pcs/5M	20pcs/5M	20pcs/5M

## DIMENSIONS (unit: mm/inch)

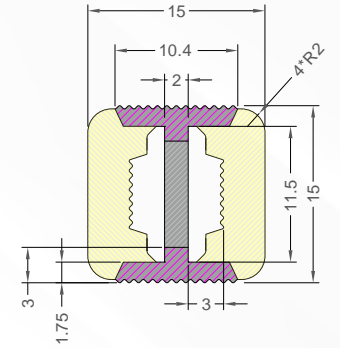
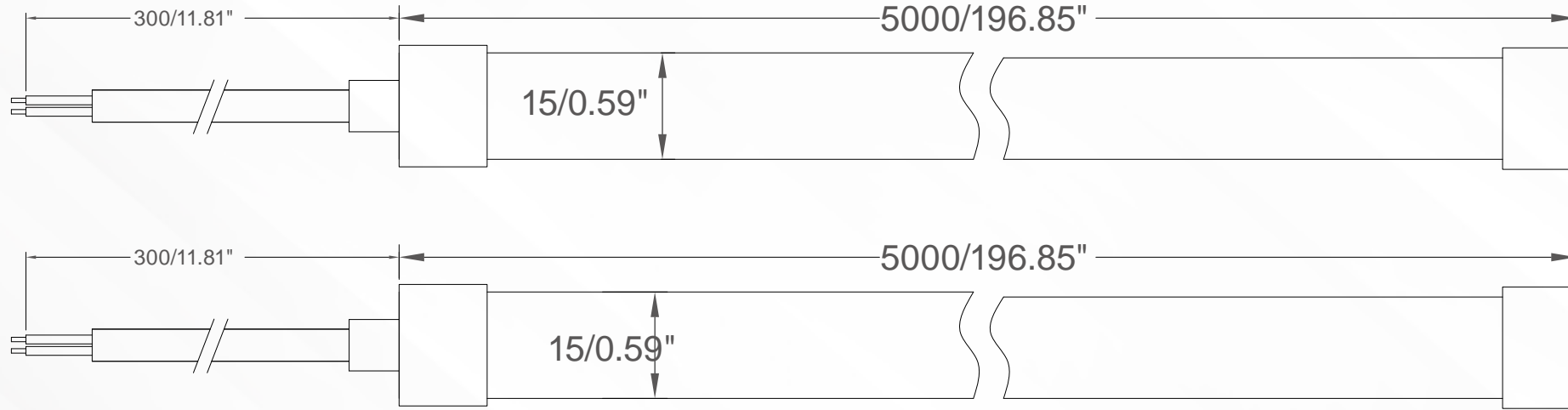



## INSTALLATION OPERATION

**Step 1:** Pull a parallel line at the location where the light strip is ready to be installed, as shown in Figure 1:

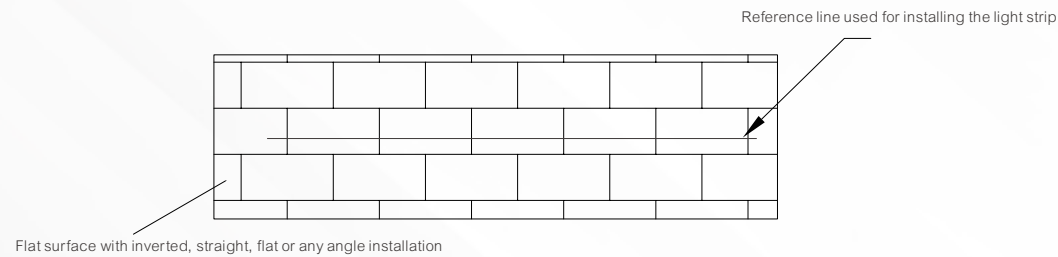

Figure 1

**Step 2:** Fix the fixed clip base on the reference line, as shown in Figure 2:



Figure 2

**Step 3:** Install the light strip into the PC clip, as shown in Figure 3:

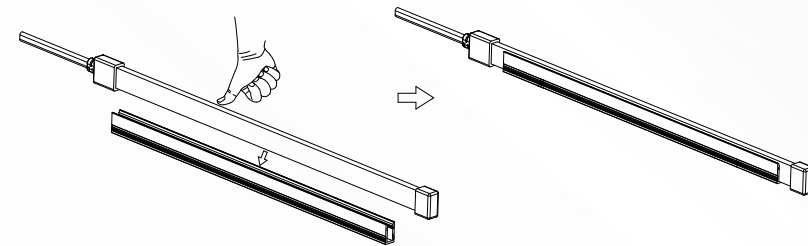

Figure 3

**Step 4:** Install the light strip into the fixed clip and complete the installation, as shown in Figure 4:

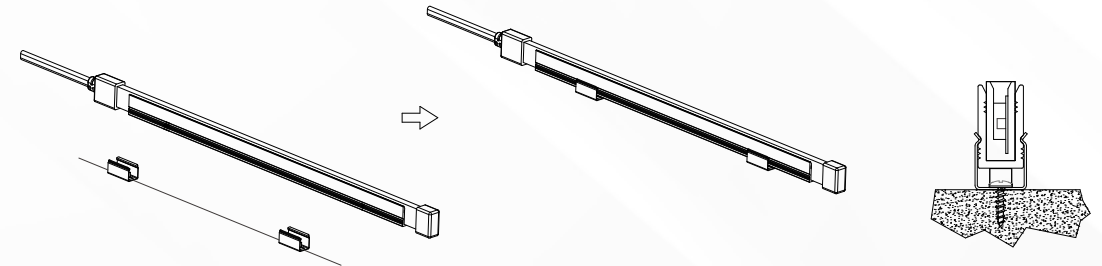
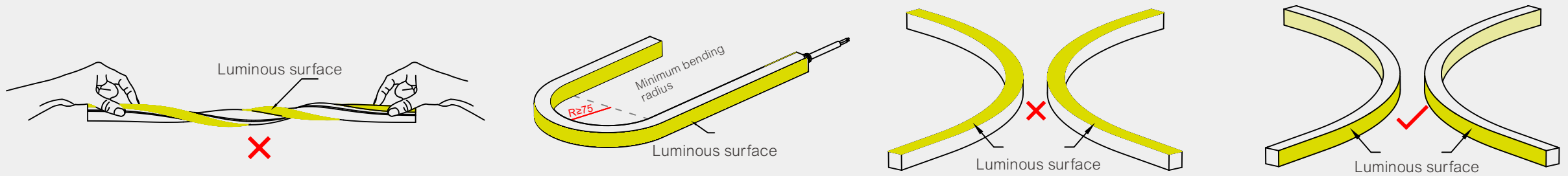
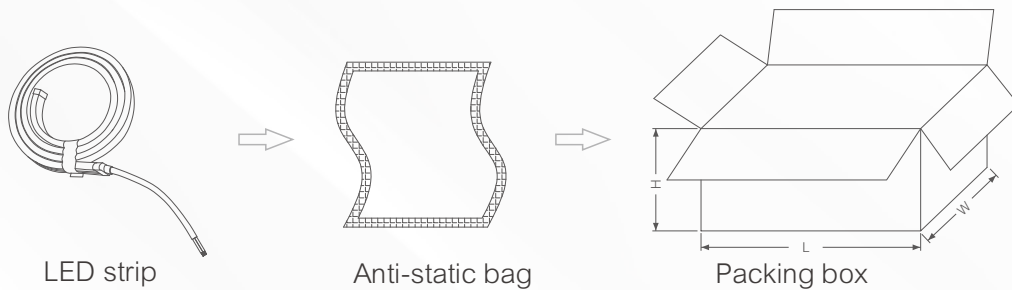

Figure 4

## BENDING DIRECTION AND BENDING RADIUS



## PACKAGING INFORMATION



LED strip+accessories	Anti-static bag		Packing Box	
Part Number	Gross Weight per Reel	QTY per Carton	Gross Weight	Size(cm/inch)
SC-(2835+5050)-TT1515W-(WW+RGB)-5-120-10-IP67	1.35KG	15	20.25KG	33cm*33cm*42.5cm 12.99"*12.99"*16.73"