



GLH Series

LED GROW LIGHT



Description



High Efficiency



Full Spectrum



Damp Location



0-10V Dimming



180° Foldable



0 DB noise



Life Span



5 Years Warranty

The GLH Series are electronic horticultural LED fixture with 6/8/9 LED light bars to be used in greenhouses or in climate-controlled rooms.



Feature

01. Slim design that foldable up to 180 degrees, making it small, compact, and easy to install.

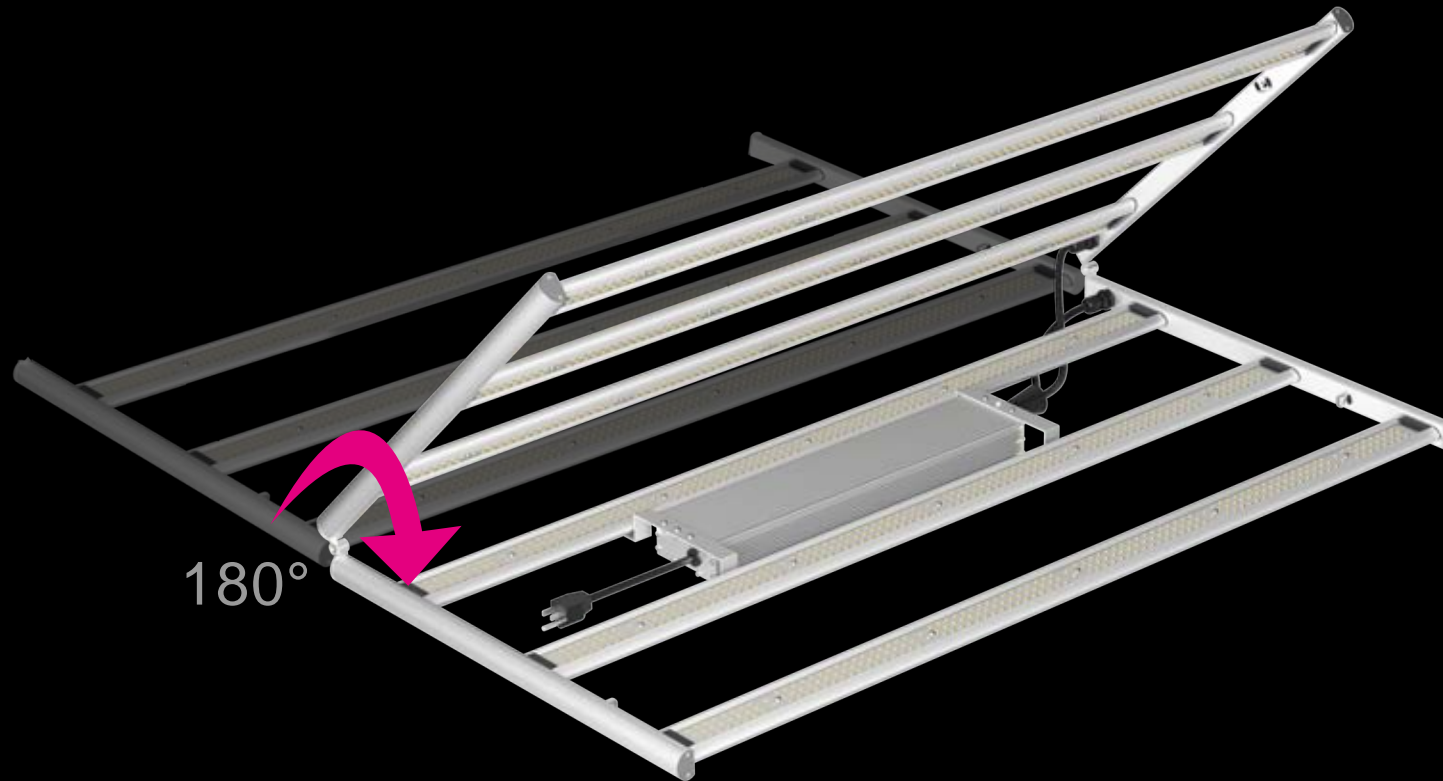

Small volume saving the transportation cost

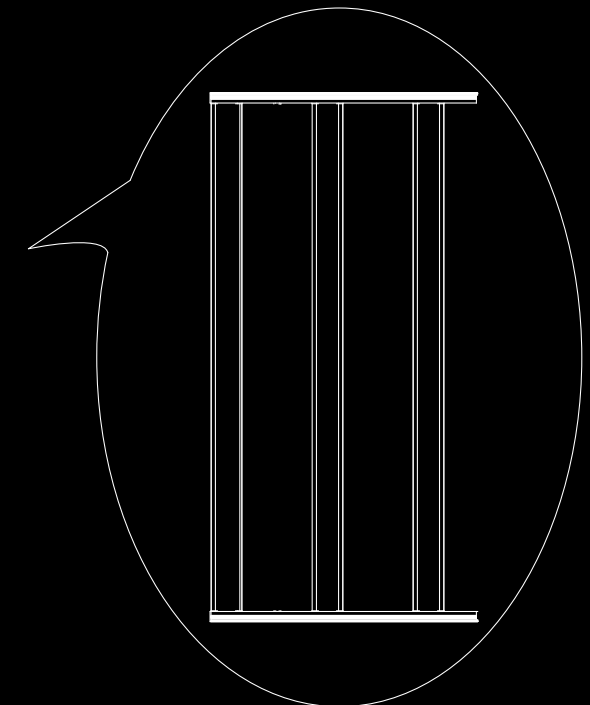

02. Intelligent brightness adjustment

Light intensity can be adjusted according to the growth needs of plants in different periods (40-100% six-level dimming)

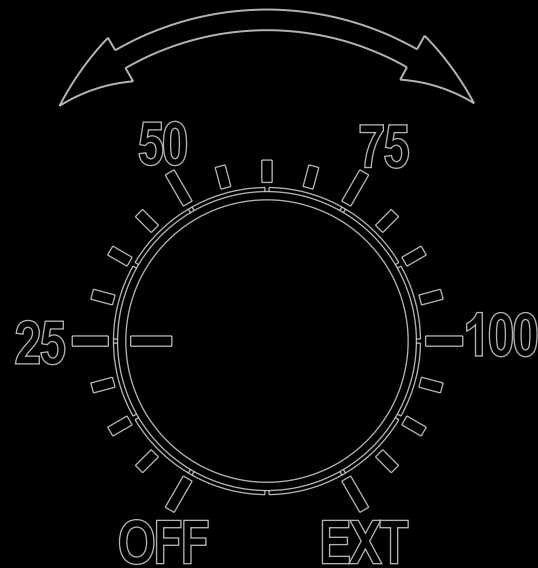

Brightness:
40%

Brightness:
40%

Brightness:
50%-60%

Brightness:
80%-100%

Brightness:
100%



Germination



Seedling



Growing



Flowering



Fruiting

APPLICATION

The product can be used in greenhouses or in climate-controlled rooms.



Technical parameters

Model	GLH-640-AW-TWL-DH02	GLH-720-AW-TWL-DH02	GLH-1000-AW-TWL-DH02
Spectrum	PhysioSpec Indoor™		
Light Output PPF	1720±50µmol/s	1940±50µmol/s	2700±100µmol/s
Efficacy	2.7 µmol/J @ 277 AC		
AC Input Power	635W @ 277V AC	715W @ 277V AC	985W @ 277V AC
AC Input Voltage	120-277V AC, 50/60Hz	120-277V AC, 50/60Hz	200-277V AC, 50/60Hz
Light Distribution	120°		
Mounting Height	6" - 12" (15.2-30.5cm) Above Canopy	6" - 12" (15.2-30.5cm) Above Canopy	6" - 12" (15.2-30.5cm) Above Canopy
Thermal Management	Passive		
Max. Ambient Temperature	95°F / 35°C		
Dimming	10 V-Source		
Total Harmonic Distortion (THD)	< 10%		
Product Dimension	L1051*W1043*H56mm	L1192*W1043*H56mm	L1576*W1043*H56mm
Item Weight	9.5Kg	11.5Kg	13.5Kg
Lifetime	L90: > 50,000hrs		
Certifications	UL 8800, FCC, Damp Location, DLC		
Warranty	5-Year Standard Warranty		

Technical parameters

Model	GLH-640-AW-TWL-D02	GLH-720-AW-TWL-D02	GLH-1000-AW-TWL-D02
Spectrum	PhysioSpec Indoor™		
Light Output PPF	1530±50µmol/s	1720±50µmol/s	2400±100µmol/s
Efficacy	2.4 µmol/J @ 277 AC		
AC Input Power	635W @ 277V AC	715W @ 277V AC	985W @ 277V AC
AC Input Voltage	120-277V AC, 50/60Hz	120-277V AC, 50/60Hz	200-277V AC, 50/60Hz
Light Distribution	120°		
Mounting Height	6" - 12" (15.2-30.5cm) Above Canopy	6" - 12" (15.2-30.5cm) Above Canopy	6" - 12" (15.2-30.5cm) Above Canopy
Thermal Management	Passive		
Max. Ambient Temperature	95°F / 35°C		
Dimming	10 V-Source		
Total Harmonic Distortion (THD)	< 10%		
Product Dimension	L1051*W1043*H56mm	L1192*W1043*H56mm	L1576*W1043*H56mm
Item Weight	9.5Kg	11.5Kg	13.5Kg
Lifetime	L90: > 50,000hrs		
Certifications	UL 8800, FCC, Damp Location, DLC		
Warranty	5-Year Standard Warranty		

Dimensions (Unit:mm/inch)

GLH-640-AW-TWL-DH02

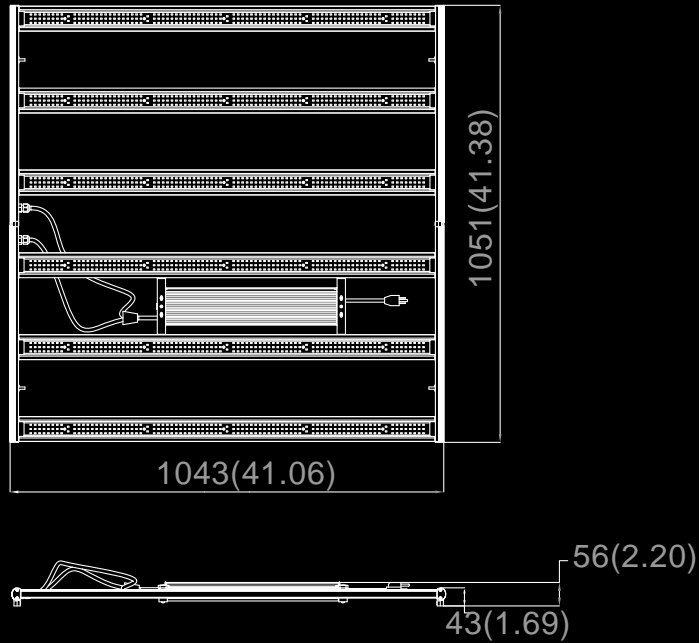

GLH-720-AW-TWL-DH02

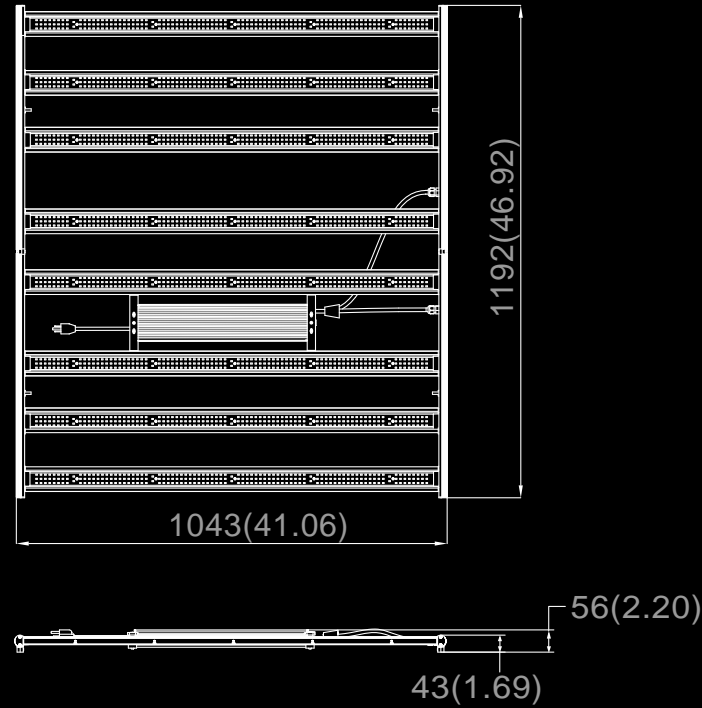

GLH-1000-AW-TWL-DH02

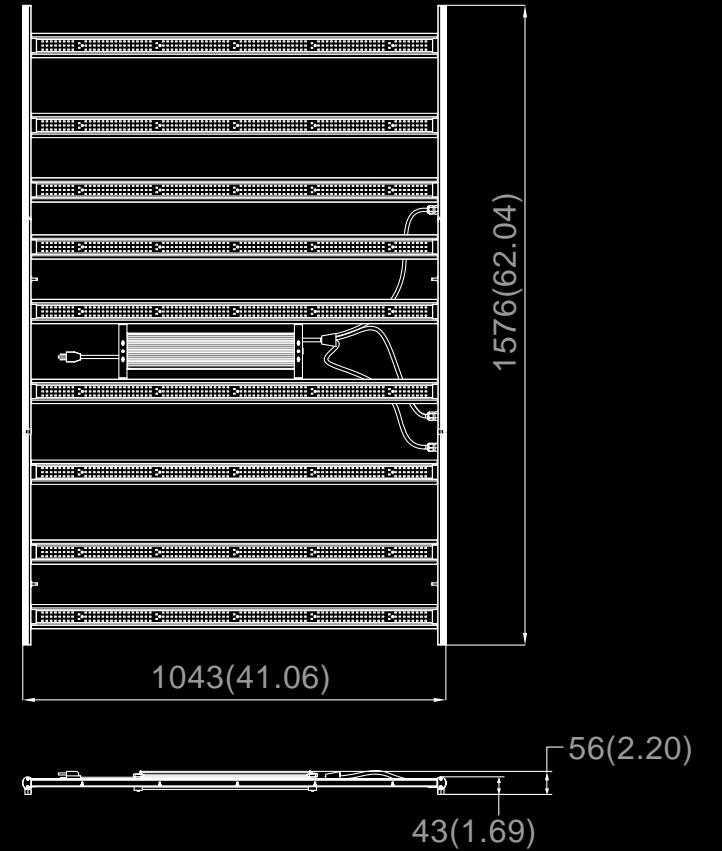

Installation

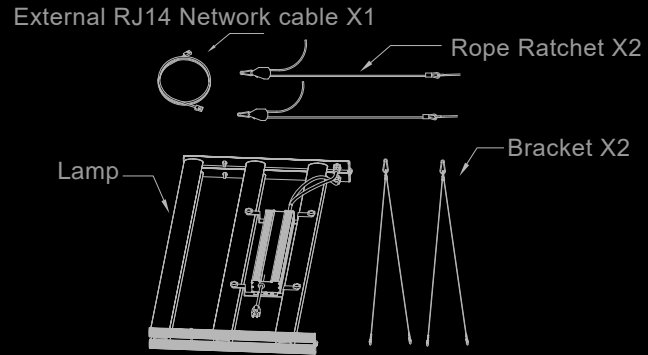

1. Unpack and take out the lamp and lamp body accessories

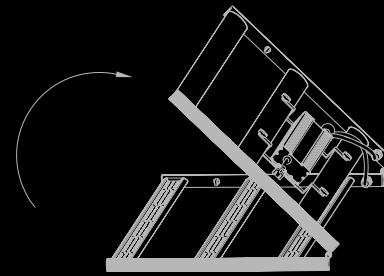

2. Place the lamp body on the workbench and unfold it

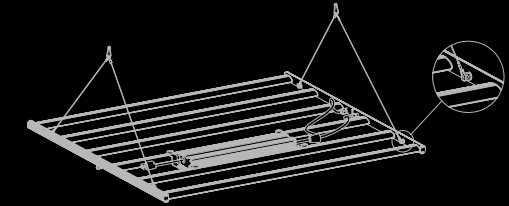

3. Fix two sets of steel wire ropes on the four hooks on the lamp

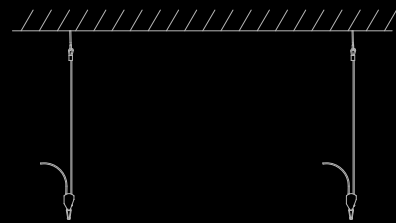

4. Fix the lifting rope on the ceiling

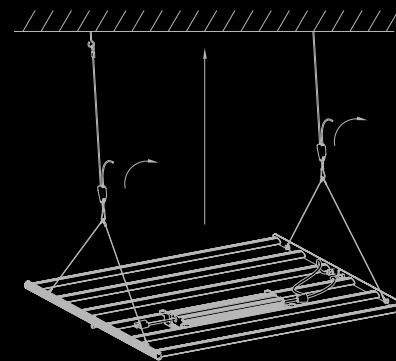

5. Hang the steel wire rope on the lifting buckle and pull the lifting rope to adjust the lamp body to a proper position

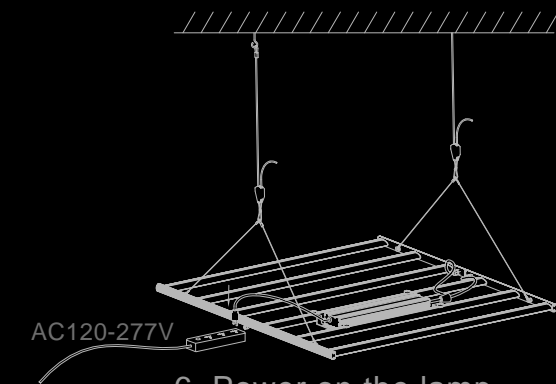

6. Power on the lamp

Package information

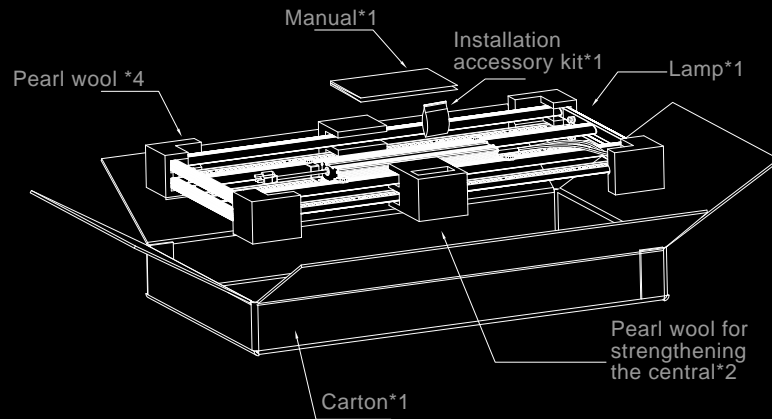

Model	Module Qty.	Carton size	PCS		
			20ft*8ft*8.5ft	40ft*8ft*8.5ft	40ft*8ft*9.5ft
GLH-640-AW-TWL-D	6	1080*615*130mm	349 PCS	731 PCS	816 PCS
GLH-720-AW-TWL-D	8	1080*685*130mm	309 PCS	636 PCS	711 PCS
GLH-1000-AW-TWL-D	9	1080*615*170mm	284 PCS	585 PCS	645 PCS

Warning! CONNECTING THE LED FIXTURE TO THE MAINS

- 1: Mounting and installing of the LED fixture may only be executed by certified service personnel, in accordance with the applicable local laws and regulations.
- 2: The installer is responsible for correct and safe installation.
- 3: Avoid coiled cords and keep mains leads separated. This prevents electromagnetic interference.
- 4: Make sure mains power is switched off before connecting the light fixture.
- 5: Caution! Ensure the cord is not coiled and does not touch any hot surfaces.
- 6: Connect the cables according to local rules, safety regulations and electrical code.
- 7: Ensure the external switching gear can cope with the inrush of electric current of the LED fixture. Always use a double pole contactor that is suitable for switching a capacitive load.
- 8: Do not connect or disconnect the LED fixture under load.