

# Smart Disc light



Color Adjustable



Android, IOS, Bluetooth



 Tuya Smart APP

 Work with  
Alexa Assistant

 Work with  
google Assistant

# Application

Used in offices, shopping malls, homes, etc. Through Bluetooth and Wifi control, users can better enjoy the fun of work and life brought by intelligent products; Meanwhile, users can download the corresponding APPs in smart terminal to realize many functions.



# Description

- **[Various colors]** The smart Disc light supports warm white and cool white from 2700K to 5000K, and R,G,B mixed colors, totally can provide 16 million different colors.
- **[APP Intelligent Control]** ①Download the "Tuya" application to connect and enjoy intelligent control ②The LED Disc Lights are intelligently grouped and controlled through the APP. ③Create a personal timetable and the downlight will switch automatically. ④Share to other devices in the APP, and share control LED lights between different devices.
- **[Voice Control]** Compatible with Alexa and Google Assistant. Use simple conversations to control your lights and release your hands.
- **[Musc& Mic Snyc]** ①The LED lights can change the color with the beat of the music or the sound of the game.②This function is only applicable to APP, no built-in microphone or speaker.
- **[High Quality]** ultra-thin body, no flicker, silent, 1%-100% smooth dimming, instant start.



Voice control

Works with the Amazon Alexa, Google Home, just make a voice command to control the light.



Remote control

Download the "Tuya Smart" APP. Via Wi-Fi or Bluetooth. You can remotely control the lights through the app.



Group Control

You can create groups for your smart lights so that you can switch them on and off with just one command at the same time.

16 Million Colors



Warm White to Daylight

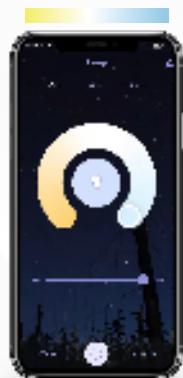

Scene simulation



Voice control.



**Bluetooth and Wifi** APP, Remote, Gateway.



**Excellent thermal management to ensure long lifetime of LED**

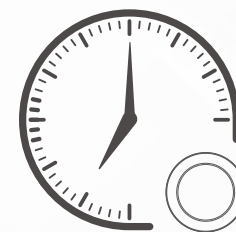

Long Life time

**50000**

hours

**High efficiency**

High efficiency and energy-saving LED driver

## Features

### Unique appearance

Beautiful design and gorgeous

### High color rendering



## Features

### Good heat dissipation

Adopt spinning iron as heat sink

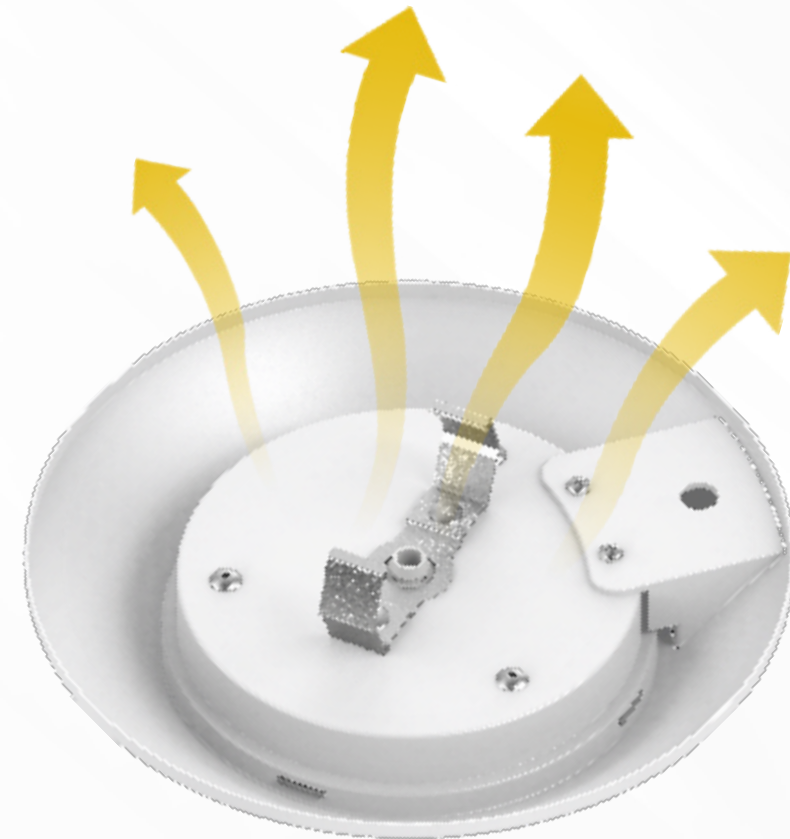

# Technical parameters

Model	CCT	Lumen(lm) (±10%)	Beam (angle)	LED Type	LED Qty.	Power(w) (±10%)	Voltage, Frequency	CRI	Control method
DL203R-4-10W-RGBTW-R90-00ZZ	2700K	580	110°	2835	Warm White 2835*14 Cold White 2835*14	10W	AC120V /60Hz	≥90	Wifi/Bluetooth
	3500K	700							
	5000K	600							
	R	16		3030	3030 RGB *40	2W		/	
	G	80							
	B	20							
DL203R-6-15W-RGBTW-R90-00ZZ	2700K	850	110°	2835	Warm White 2835*14 Cold White 2835*14	15W	AC120V /60Hz	≥90	Wifi/Bluetooth
	4000K	1000							
	5000K	900							
	R	16		3030	3030 RGB *40	2W		/	
	G	80							
	B	20							

◎ The “ZZ” can be any numbers from 01 to 99 denotes commercial code for commercial use;

# Dimensions (Unit: mm)

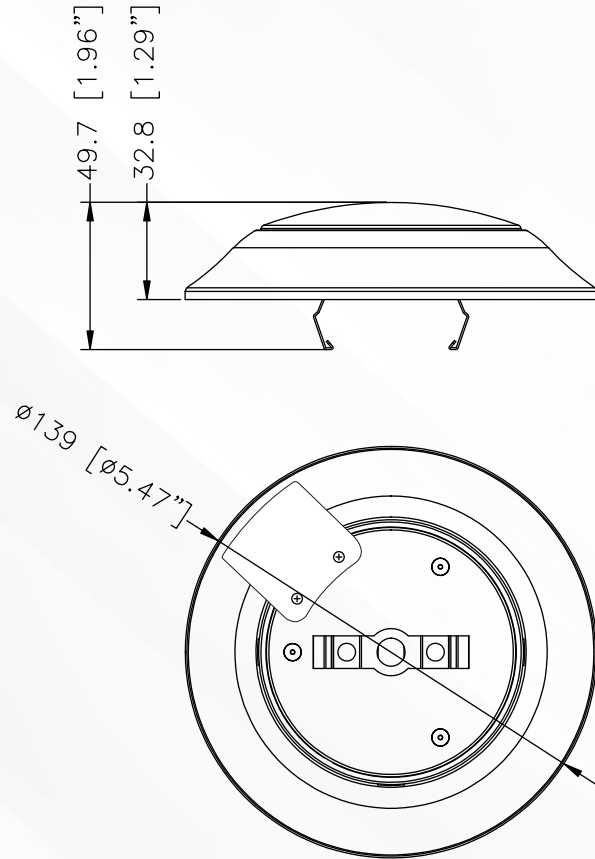

DL203R 4inch

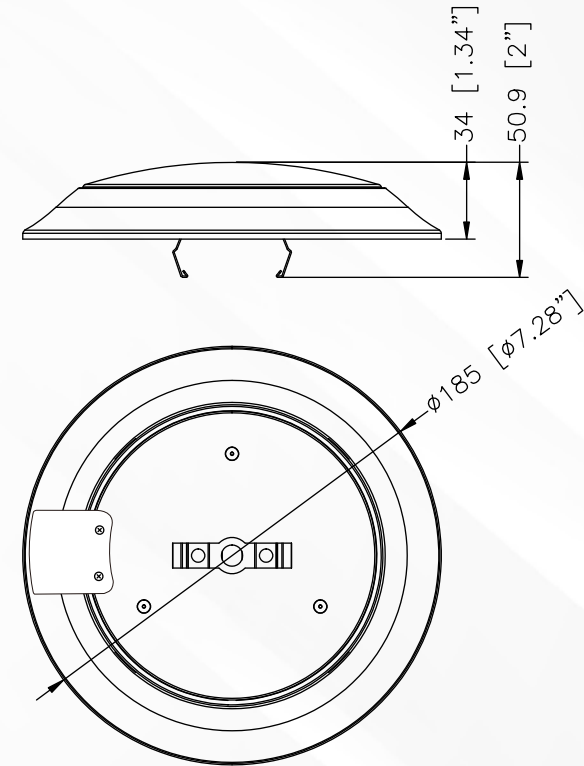

DL203R 6inch

# Installation (DL203R 4inch)

## ACCESSORIES:



M5 Screw(2pcs)  
for 4"shrapnel



#8-32 Screw(2pcs)  
for J-BOX



Wire nut(3pcs)  
for J-BOX and recessed mount



Mounting brackets

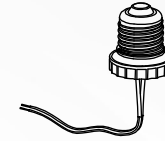

E26 base(1pcs)  
for recessed mount

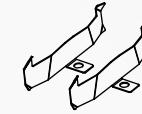

4"shrapnel(2pcs)  
for 4"recessed mount

## For J-BOX



Figure1

Junction box

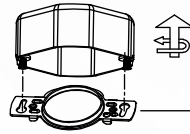

Figure2

Mounting brackets

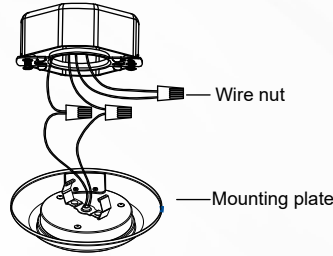

Figure3

Mounting plate

Wire nut

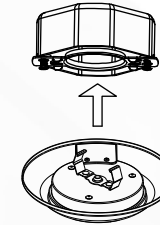

Figure3

## For 4" can install

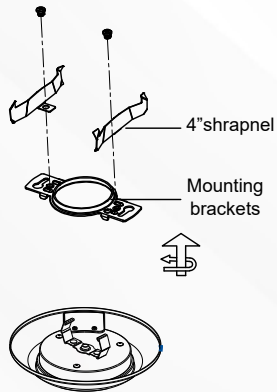

Figure1

4"shrapnel

Mounting brackets

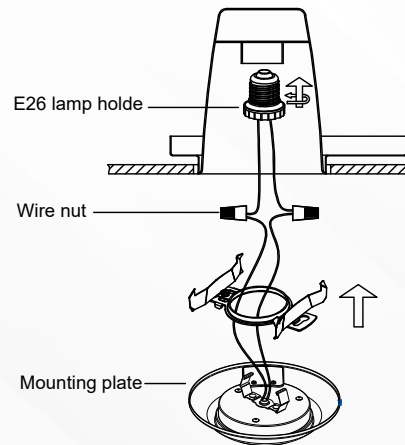

Figure2

E26 lamp holde

Wire nut

Mounting plate

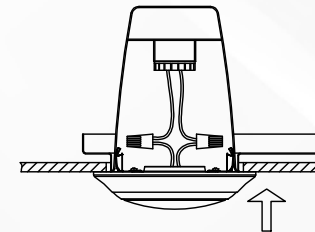
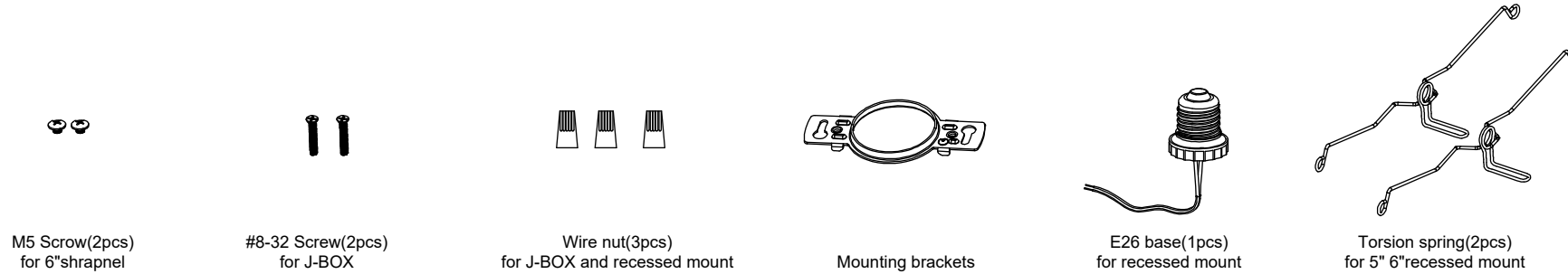

Figure3

# Installation (DL203R 6inch)

## ACCESSORIES:



## For J-BOX

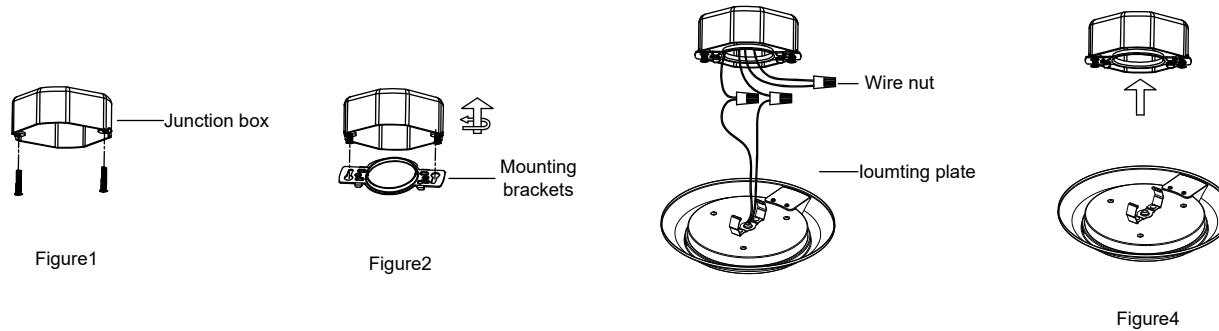

## For 5" 6" can install

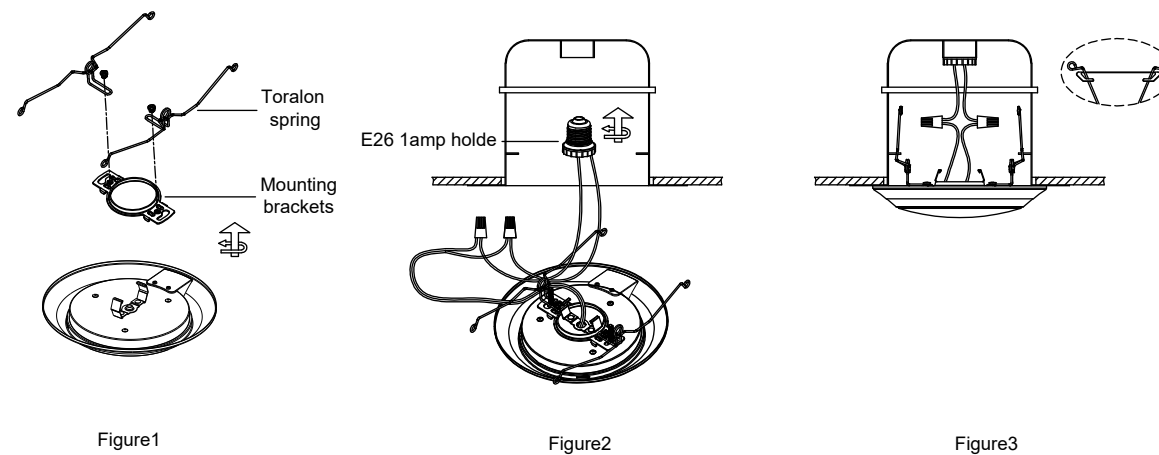



# Packing information

Model	Color box size	External case	Net weight	Weight of whole
DL203R 4inch	141*52*141mm	439*438*297mm 48PCS/CN	0.136kg	7.72kg
DL203R 6inch	187*53*187mm	439*374*389mm 32PCS/CN	0.235kg	8.86kg

## WARNING



- ⦿ “WARNING - Risk of fire or electric shock. LED Retrofit Kit installation requires knowledge of luminaires electrical systems. If not qualified, do not attempt to install. Contact a qualified electrician.” or equivalent in Format S24-L5.
- ⦿ “WARNING - Risk of fire or electric shock. Install this kit only in luminaires that have the construction features and dimensions shown in the photographs and/or drawings and where the input rating of the retrofit kit does not exceed the input rating of the luminaire.” or equivalent in Format S24-L5.
- ⦿ “Do not make or alter any open holes in an enclosure of wiring or electrical components during kit installation.” Verbatim in Format S24-L5.
- ⦿ “WARNING - To prevent wiring damage or abrasion, do not expose wiring to edges of sheet metal or other sharp objects.” or equivalent in Format S24-L5.
- ⦿ “This product must be installed in accordance with the applicable installation code by a person familiar with the construction and operation of the product and the hazards involved” or equivalent in Format S24-L4.