

DISC Series

DL205T-4-10W-5CCT/ DL205T-6-15W-5CCT

2700K	3000K	3500K	4000K	5000K
Warm white	Warm white	Warm white	Natural white	White



Application

Suitable for hotel, corridor, home decoration, shopping mall, exhibition room, etc.



Features

Good heat dissipation

Adopt spinning iron as heat sink

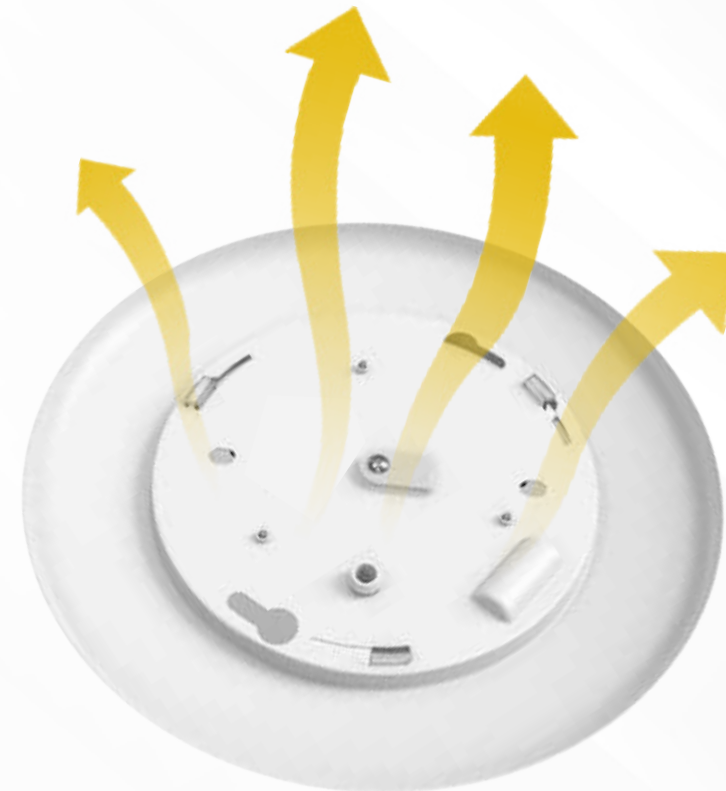

Description

DISC downlight for 120V AC ,10W/15W. Available triac dimmable and non dimming.

DISC downlight can fit 4" junction box and

replace of most 4" and 6" surface mount downlights;

DISC downlight can fit 4" & 5" & 6" downlight housings

and replace of most 4" & 5" & 6" recessed downlights;

This product is ideal for use in many residential and commercial lighting applications with E26 base.

Features

Unique appearance

Beautiful design and gorgeous

High color rendering

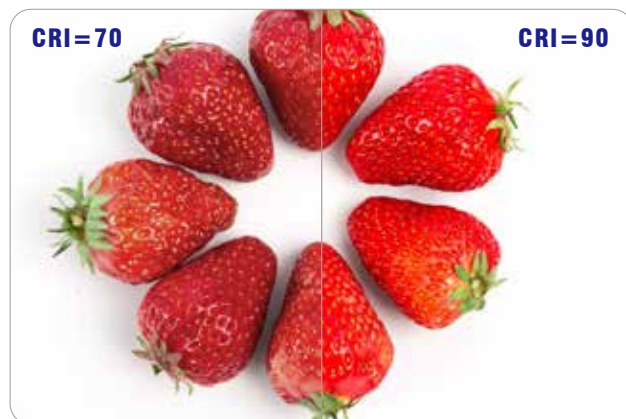

Excellent thermal management to ensure long lifetime of LED

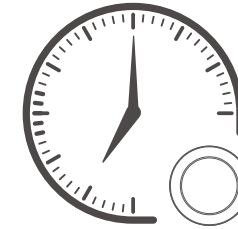

Long Life time

50000

hours

High efficiency

High efficiency and energy-saving LED driver

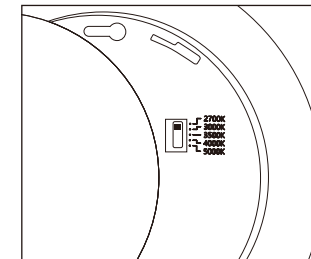

Locate the CCT switch on center of the disk and select your desired setting.

Features

Selectable color temperature (2700K, 3000K, 3500K, 4000K, 5000K)

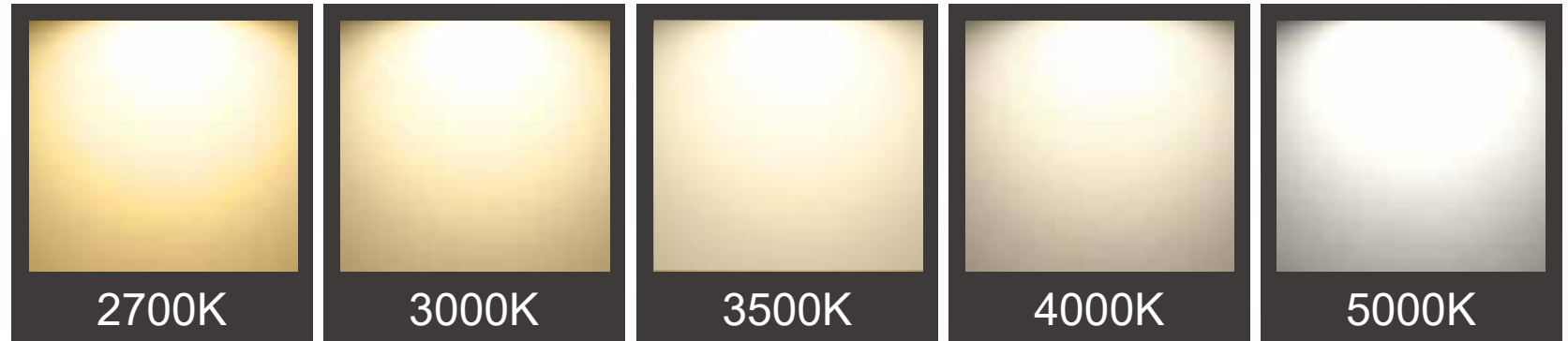

Triac dimmable / Non dimming

This product is suitable for use in dimming circuit. For 10-100% light control, use with a compatible dimmer. Compatible dimmers include most standard dimmers, such as Lutron : SCL-153P, CTCL-153P, DVCL-153P, MACL-153M, MACL-153MR-WH, CL-6674, TG-600PH-LA, CL-6683, IPLO6, CL-6672, MACL-153M, EDV-600P, 153M-ES.

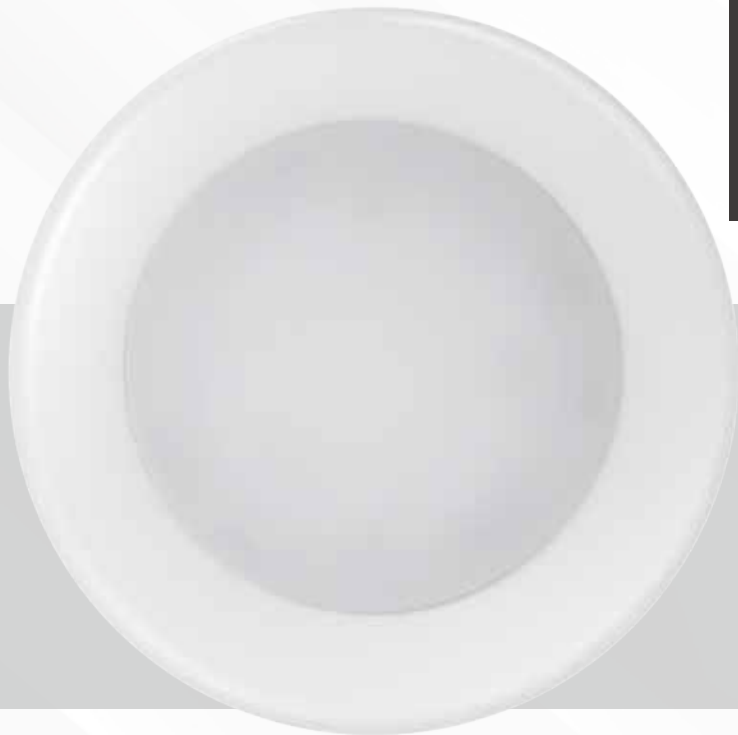

Technical parameters

Model	CCT	Lumen(lm)(±10%)	Beam(a ngle)	LED Type	LED Qty.	Power(w) (±10%)	Voltage, Frequency	CRI	PF	Dimming Type	Control method
DL205T-4-10W-5CCT-R90-00ZZ	2700K	600	110°	2835	Warm White: 2835*14 Cold White: 2835*14	10W	AC120V/60Hz	≥90	>0.9	Triac dimmable	Change color temperature by dial switch
	3000K	610									
	3500K	600									
	4000K	600									
	5000K	610									
DL205T-6-15W-5CCT-R90-00ZZ	2700K	910	110°	2835	Warm White: 2835*14 Cold White: 2835*14	15W	AC120V/60Hz	≥90	>0.9	Triac dimmable	Change color temperature by dial switch
	3000K	950									
	3500K	900									
	4000K	910									
	5000K	1000									

- The “ZZ” can be any numbers from 01 to 99 denotes commercial code for commercial use ;
- The above parameters are the parameters of the white shell lamp

Dimensions (Unit: mm)

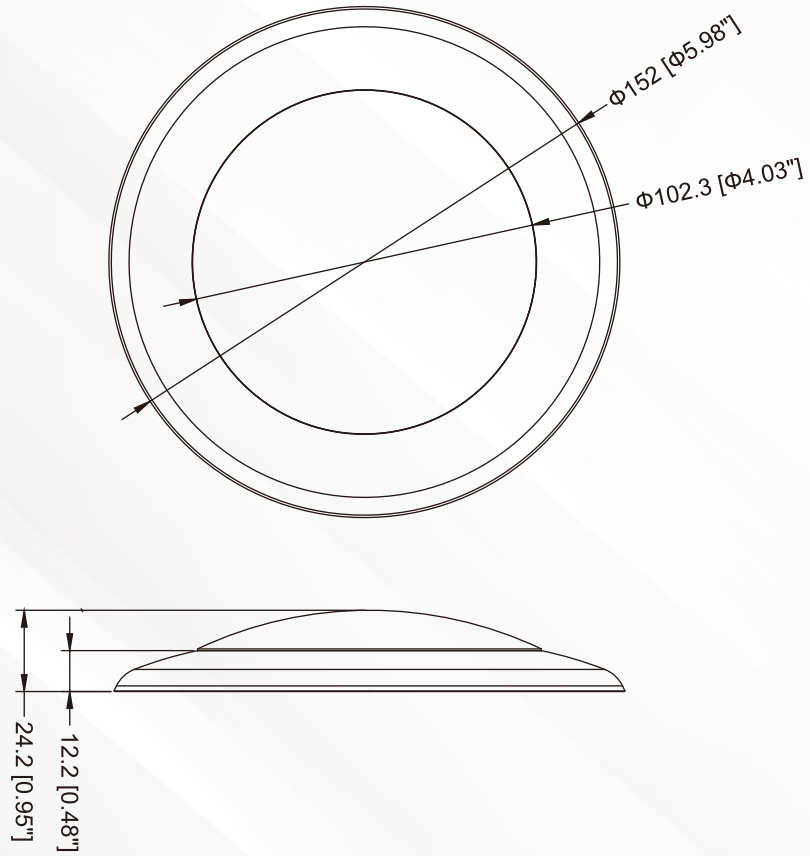

DL205T 4inch

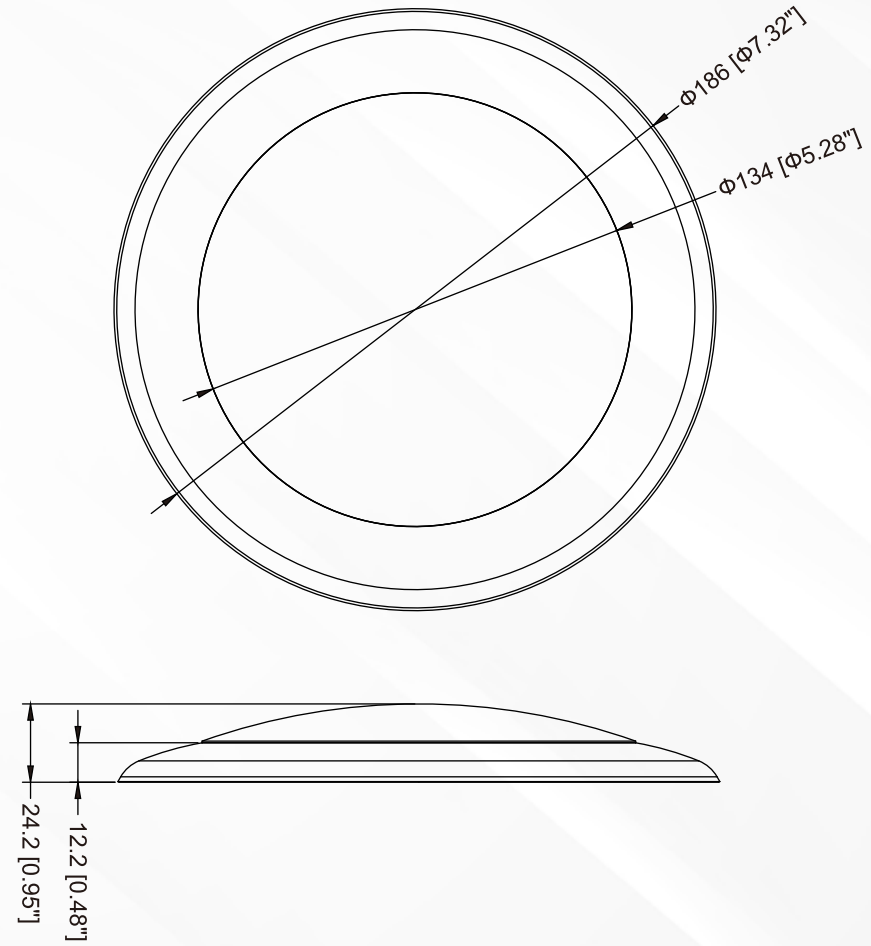

DL205T 6inch

ACCESSORIES (DL205T—4")

Standard:

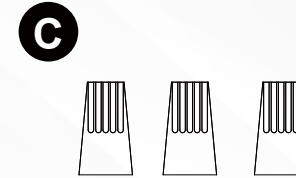
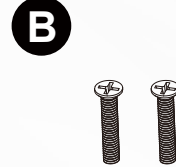
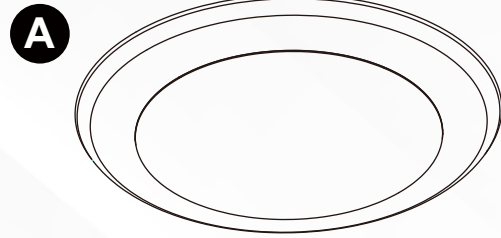

Optional accessories:

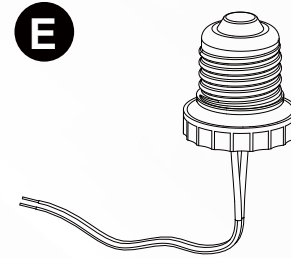
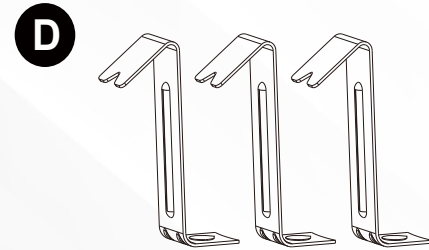

	PART	DESCRIPTION	QUANTITY
Standard:	A	4in Round LED Disc	1
	B	Mounting Screws	2
	C	Wire nut	3
Optional: accessories:	D	Mounting Bracket(4" Fixture Only)	3
	E	E26 Base Whip	1
	F	Mounting Screws	3

ACCESSORIES (DL205T—6")

Standard: **A**

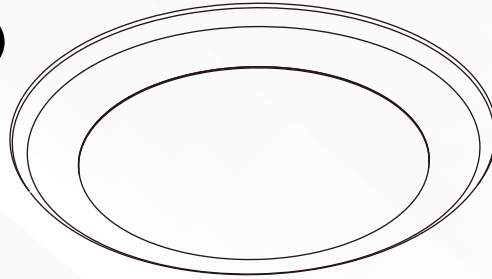

B



C

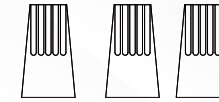

Optional accessories: **D**

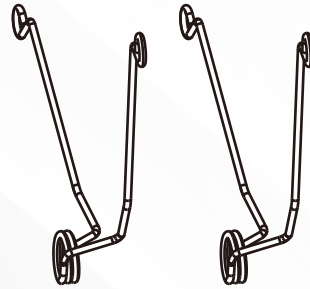

E

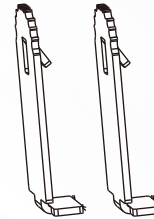

F

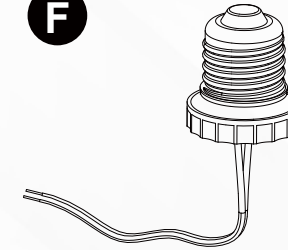

	PART	DESCRIPTION	QUANTITY
Standard:	A	6in Round LED Disc	1
	B	Mounting Screws	2
	C	Wire nut	3
Optional: accessories:	D	Spring iron support	2
	E	Mounting iron	2
	F	E26 Base Whip	1

Installation(DL205T—4")

For J-BOX Installation

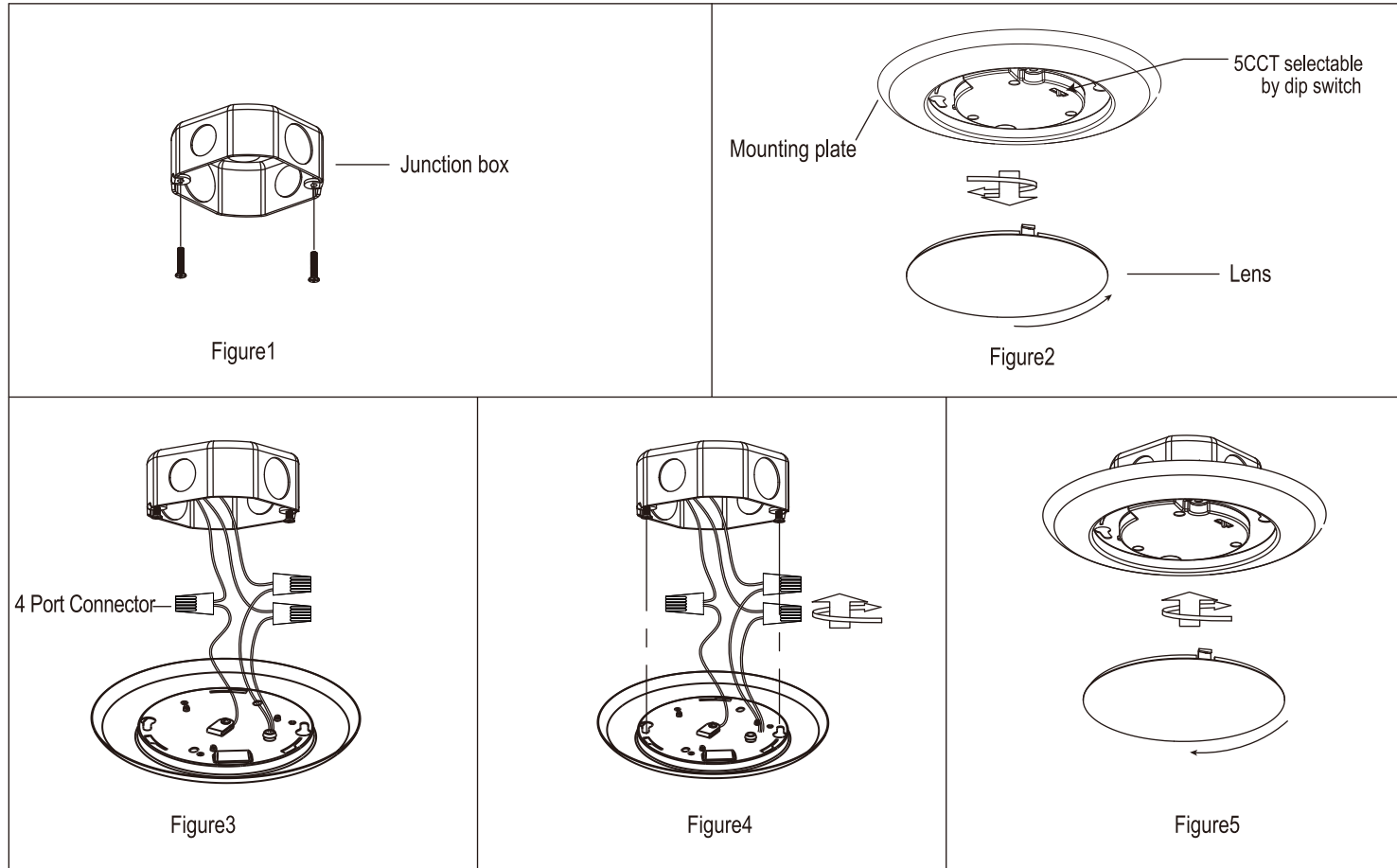

Installation(DL205T—4")

For Can Installation



Figure1

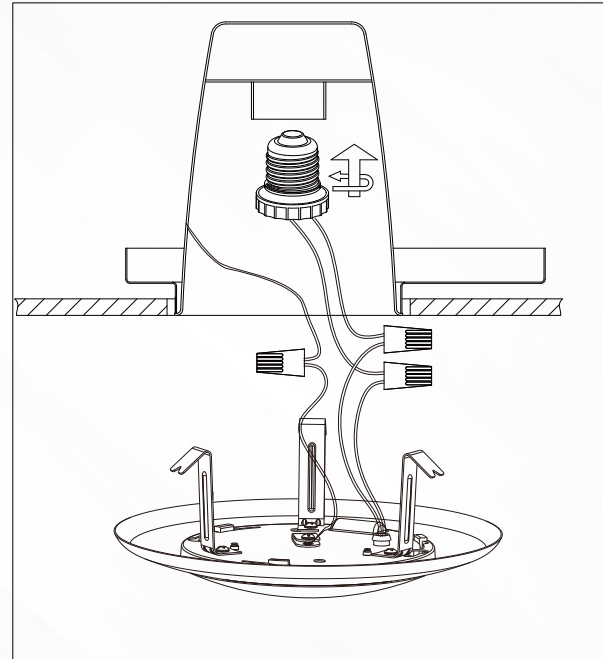

Figure2

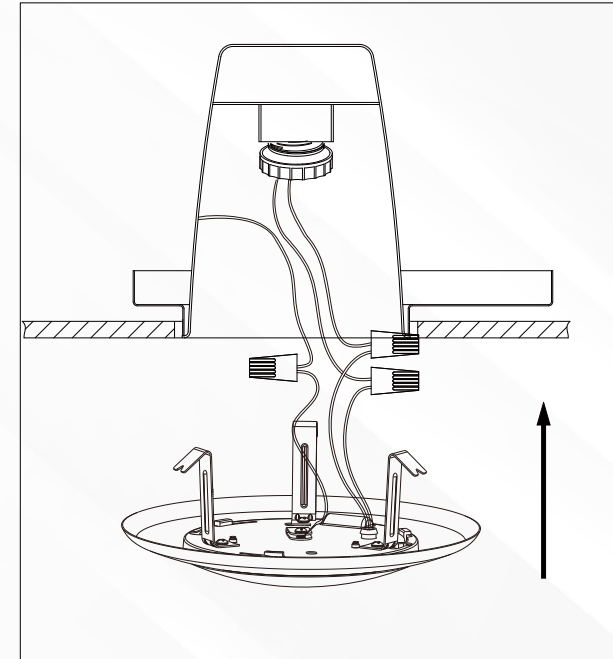
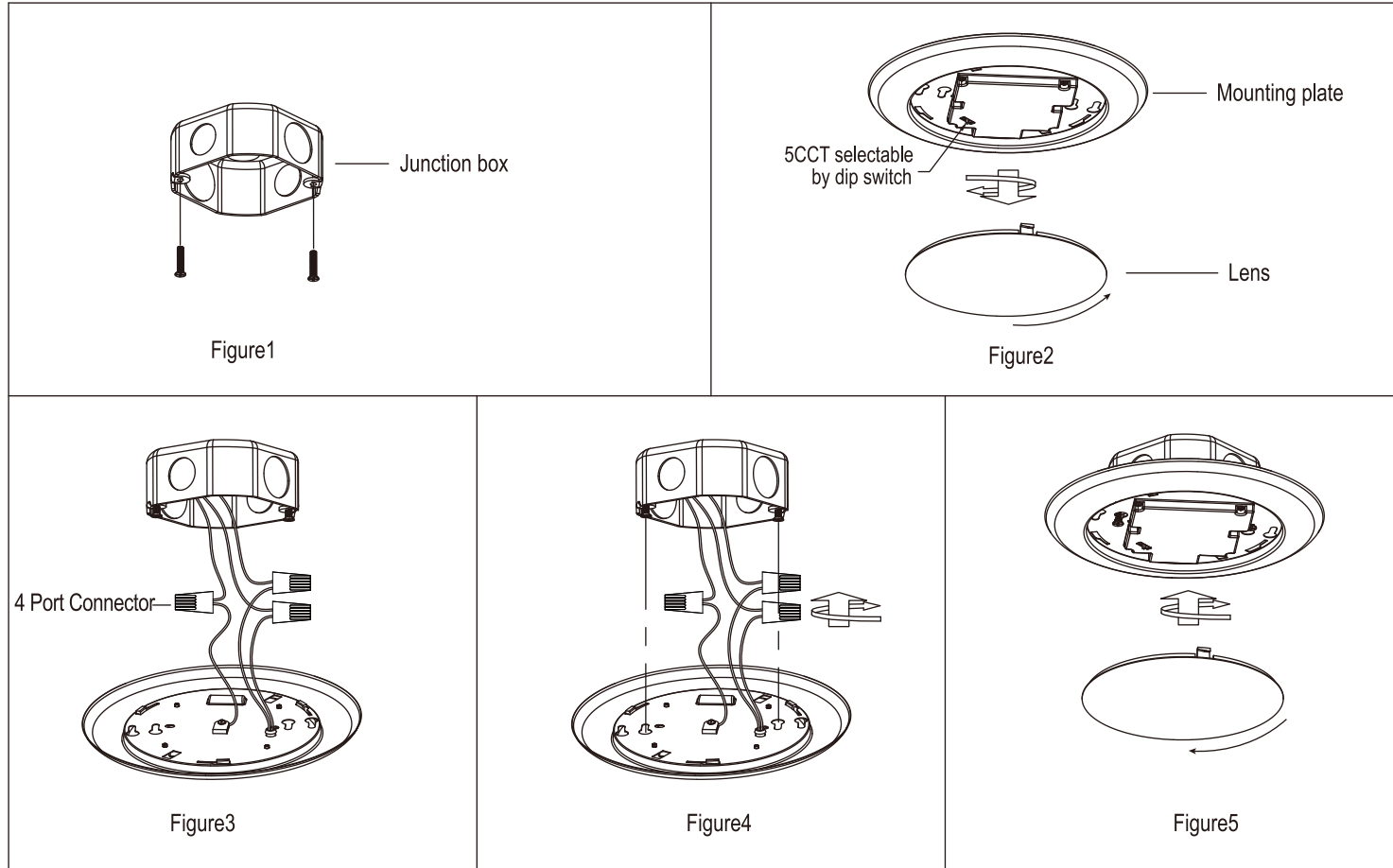

Figure3

Installation(DL205T —6")

For J-BOX Installation



Installation(DL205T —6")

For Can Installation

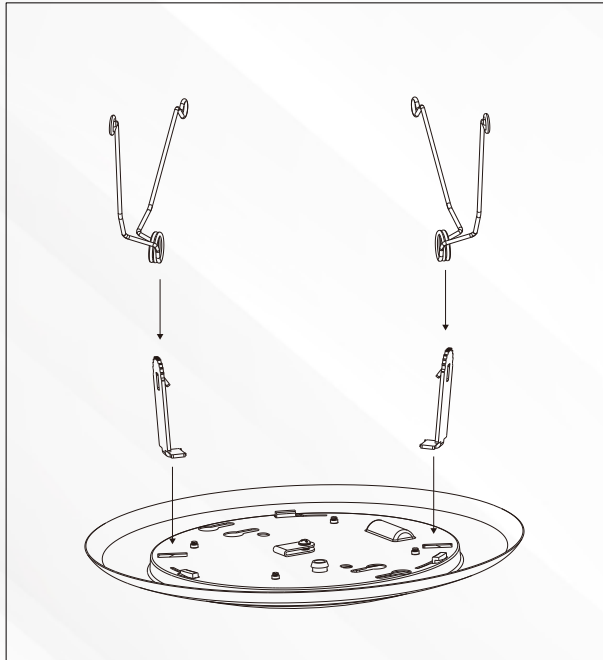

Figure1

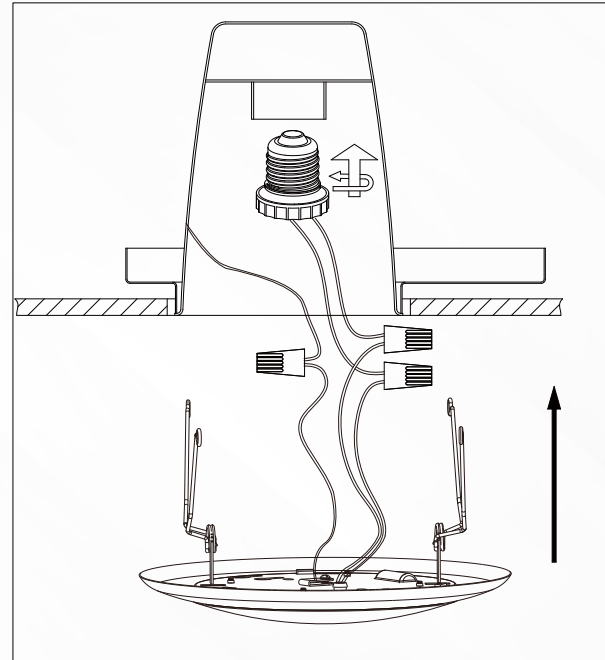

Figure2

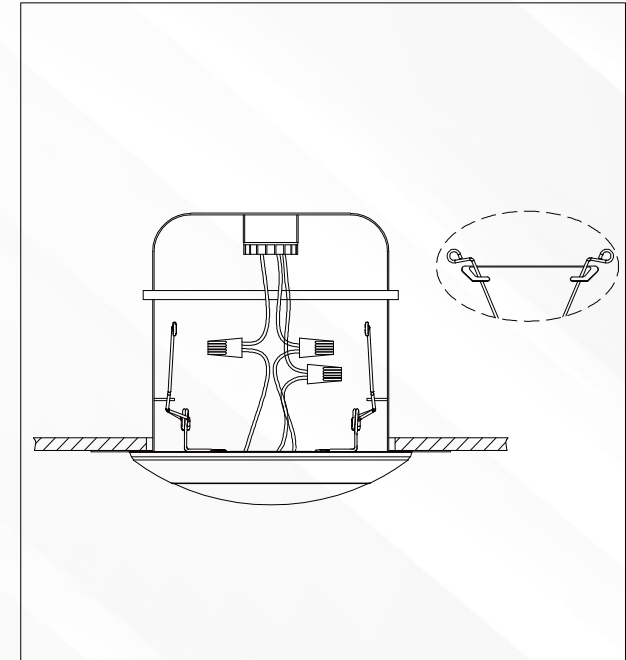

Figure3

Packing information

Model	Color box size	External case	Net weight	Weight of single	Weight of whole
DL205T 4inch	156*32*158mm	494*190*337mm/30PCS	0.130kg	0.199kg	6.484kg
DL205T 6inch	190*32*192mm	403*224*405mm/24PCS	0.186kg	0.278kg	7.452kg

WARNING



- ⦿ “WARNING - Risk of fire or electric shock. LED Retrofit Kit installation requires knowledge of luminaires electrical systems. If not qualified, do not attempt to install. Contact a qualified electrician.” or equivalent in Format S24-L5.
- ⦿ “WARNING - Risk of fire or electric shock. Install this kit only in luminaires that have the construction features and dimensions shown in the photographs and/or drawings and where the input rating of the retrofit kit does not exceed the input rating of the luminaire.” or equivalent in Format S24-L5.
- ⦿ “Do not make or alter any open holes in an enclosure of wiring or electrical components during kit installation.” Verbatim in Format S24-L5.
- ⦿ “WARNING - To prevent wiring damage or abrasion, do not expose wiring to edges of sheet metal or other sharp objects.” or equivalent in Format S24-L5.
- ⦿ “This product must be installed in accordance with the applicable installation code by a person familiar with the construction and operation of the product and the hazards involved” or equivalent in Format S24-L4.