

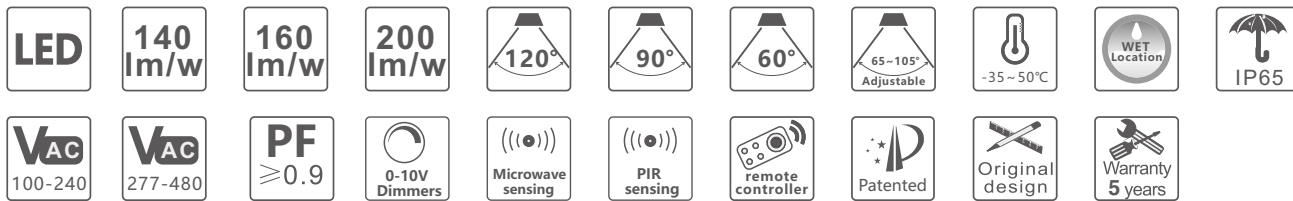

Cibay-B High Bay Light CE Type



Feature:

1. Multifunctional and expandable interface, plug&play module, no need wiring, save labor costs.
2. High efficiency LED, 140lm/w, 160lm/w, 200lm/w multiple brightness levels optional.
3. Adjustable angle, support three-speed adjustment of 65, 90, 105 degrees ,it can freely switch according to needs (IP40)
4. There are three adjustable levels of color temperature , two-color LEDs are equally spaced and symmetrically distributed, with uniform color mixing;
5. Adjustable power, It can be set to 80W 100W 120W, 80W 100W 120W 150W, 100W 120W 150W 200W ,it can freely switch according to needs .
6. 200LM/W,with the world's highest light efficiency, Compared with traditional light sources, it can save more than 85% of energy efficiency;
7. The LEDs are arranged symmetrically in a circle, so that heat source can be evenly distributed, have high efficient heat conduction.
8. UV-resistant PC material optics, IK08 impact resistance grade.
9. Working temperature: -35 °C ~ + 50 °C.
10. Suitable for damp environment, slight corrosion-proof grade indoors.
11. Regular products provide Warranty is 5 years.



Application

Suitable for large workshop, airport, warehouse, parking lot, basement, gymnasium etc.

*** Traditional product can't be used outdoors**

*** Suitable for damp environment, slight corrosion-proof grade indoors**



Description

CIBAY-B series products have reserved sensor socket, the socket is Signcomplex own patent design, can install the sensors in 3 seconds, plug and play, no need wiring, hugely save labor costs. You can easily get the function you need by insert the correspond sensors like Microwave, PIR, Bluetooth sensor etc, customers can easily install and replace sensors themselves, very convenient and practical. Cibay-B has the same accessories support as cibay-S, such as optical lens, lampshade, installation device, etc. the two series of products can be common parts with each other, which can improve the efficiency of inventory transfer.

CIBAY-B adjustable-angle series, support rotation switching at 65, 90, 105 degrees , it can be adjusted by free-hand without tools, easy to deal with various scenarios.

Technical parameters

Model	CCT	Lumen(lm) ±10%	Beam (angle°) ±10%	LEDs type CRI	Power(w) ±10%	Voltage Frequency	Notes
CBB-100-AW-60K-D001	6000k	13400	120、90、60°	SMD Ra > 80	100W	AW:100-240VAC 50-60Hz,Max1.2A	140lm/W
CBB-100-AW-50K-D001	5000k	13400					
CBB-100-AW-40K-D001	4000k	13270					
CBB-100-AW-30K-D001	3000k	12300					
CBB-150-AW-60K-D001	6000k	20190	120、90、60°	SMD Ra > 80	150W	AW:100-240VAC 50-60Hz,Max1.8A	
CBB-150-AW-50K-D001	5000k	20190					
CBB-150-AW-40K-D001	4000k	19830					
CBB-150-AW-30K-D001	3000k	18480					
CBB-200-AW-60K-D001	6000k	27260	120、90、60°	SMD Ra > 80	200W	AW:100-240VAC 50-60Hz,Max2.3A	
CBB-200-AW-50K-D001	5000k	27260					
CBB-200-AW-40K-D001	4000k	26840					
CBB-200-AW-30K-D001	3000k	24810					
CBB-240-AW-60K-D001	6000k	32340	120、90、60°	SMD Ra > 80	240W	AW:100-240VAC 50-60Hz,Max2.7A	
CBB-240-AW-50K-D001	5000k	32340					
CBB-240-AW-40K-D001	4000k	32170					
CBB-240-AW-30K-D001	3000k	29850					
CBB-100-HV-60K-D003	6000k	13400	120、90、60°	SMD Ra > 80	100W	HV:277-480VAC 50-60Hz,Max0.60A	
CBB-100-HV-50K-D003	5000k	13400					
CBB-100-HV-40K-D003	4000k	13270					
CBB-100-HV-30K-D003	3000k	12300					
CBB-150-HV-60K-D003	6000k	20190	120、90、60°	SMD Ra > 80	150W	HV:277-480VAC 50-60Hz,Max0.85A	
CBB-150-HV-50K-D003	5000k	20190					
CBB-150-HV-40K-D003	4000k	19830					
CBB-150-HV-30K-D003	3000k	18480					
CBB-200-HV-60K-D003	6000k	27260	120、90、60°	SMD Ra > 80	200W	HV:277-480VAC 50-60Hz,Max1.20A	
CBB-200-HV-50K-D003	5000k	27260					
CBB-200-HV-40K-D003	4000k	26840					
CBB-200-HV-30K-D003	3000k	24810					
CBB-240-HV-60K-D003	6000k	32340	120、90、60°	SMD Ra > 80	240W	HV:277-480VAC 50-60Hz,Max1.40A	
CBB-240-HV-50K-D003	5000k	32340					
CBB-240-HV-40K-D003	4000k	32170					
CBB-240-HV-30K-D003	3000k	29850					
CBB-100-AW-60K-D101	6000k	16000	120、90、60°	SMD Ra > 80	100W	AW:100-240VAC 50-60Hz,Max1.2A	160lm/W
CBB-100-AW-50K-D101	5000k	16000					
CBB-100-AW-40K-D101	4000k	15600					
CBB-100-AW-30K-D101	3000k	14800					
CBB-150-AW-60K-D101	6000k	24150	120、90、60°	SMD Ra > 80	150W	AW:100-240VAC 50-60Hz,Max1.8A	
CBB-150-AW-50K-D101	5000k	24150					
CBB-150-AW-40K-D101	4000k	23550					
CBB-150-AW-30K-D101	3000k	22350					
CBB-200-AW-60K-D101	6000k	32200	120、90、60°	SMD Ra > 80	200W	AW:100-240VAC 50-60Hz,Max2.3A	
CBB-200-AW-50K-D101	5000k	32200					
CBB-200-AW-40K-D101	4000k	31400					
CBB-200-AW-30K-D101	3000k	29800					
CBB-240-AW-60K-D101	6000k	38400	120、90、60°	SMD Ra > 80	240W	AW:100-240VAC 50-60Hz,Max2.7A	
CBB-240-AW-50K-D101	5000k	38400					
CBB-240-AW-40K-D101	4000k	37450					
CBB-240-AW-30K-D101	3000k	35500					
CBB-100-AW-TCK-D001	6000k 4500k 3000k	13500 14100 11800	120、90、60°	SMD Ra > 80	100W	AW:100-240VAC 50-60Hz,Max1.2A	CCT Tunable 140lm/W
CBB-150-AW-TCK-D001	6000k 4500k 3000k	20250 21150 17700	120、90、60°	SMD Ra > 80	150W	AW:100-240VAC 50-60Hz,Max1.8A	
CBB-200-AW-TCK-D001	6000k 4500k 3000k	27000 28200 23600	120、90、60°	SMD Ra > 80	200W	AW:100-240VAC 50-60Hz,Max2.3A	
CBB-240-AW-TCK-D001	6000k 4500k 3000k	32400 33840 28320	120、90、60°	SMD Ra > 80	240W	AW:100-240VAC 50-60Hz,Max2.7A	

Model	CCT	Lumen(lm) ±10%	Beam (angle°) ±10%	LEDs type CRI	Power(w) ±10%	Voltage Frequency	Notes
CBB-100-AW-60K-DA01	6000k	19100					
CBB-100-AW-50K-DA01	5000k	19100					
CBB-100-AW-40K-DA01	4000k	18600	120, 90, 60°	SMD Ra > 70	100W	AW:100-240VAC 50-60Hz,Max1.2A	
CBB-100-AW-30K-DA01	3000k	17500					
CBB-120-AW-60K-DA01	6000k	22900					
CBB-120-AW-50K-DA01	5000k	22900	120, 90, 60°	SMD Ra > 70	120W	AW:100-240VAC 50-60Hz,Max1.4A	
CBB-120-AW-40K-DA01	4000k	22300					
CBB-120-AW-30K-DA01	3000k	21000					
CBB-150-AW-60K-DA01	6000k	28650					
CBB-150-AW-50K-DA01	5000k	28650	120, 90, 60°	SMD Ra > 70	150W	AW:100-240VAC 50-60Hz,Max1.8A	200lm/W
CBB-150-AW-40K-DA01	4000k	27900					
CBB-150-AW-30K-DA01	3000k	26400					
CBB-200-AW-60K-DA01	6000k	38200					
CBB-200-AW-50K-DA01	5000k	38200	120, 90, 60°	SMD Ra > 70	200W	AW:100-240VAC 50-60Hz,Max2.3A	
CBB-200-AW-40K-DA01	4000k	37200					
CBB-200-AW-30K-DA01	3000k	35200					
CBB-240-AW-60K-DA01	6000k	45800					
CBB-240-AW-50K-DA01	5000k	45800	120, 90, 60°	SMD Ra > 70	240W	AW:100-240VAC 50-60Hz,Max2.7A	
CBB-240-AW-40K-DA01	4000k	44600					
CBB-240-AW-30K-DA01	3000k	42200					
CBB-100-AW-60K-D0L1	6000k	13400					
CBB-100-AW-50K-D0L1	5000k	13400	65-90~105°	SMD Ra > 80	100W	AW:100-240VAC 50-60Hz,Max1.2A	
CBB-100-AW-40K-D0L1	4000k	13270					
CBB-100-AW-30K-D0L1	3000k	12300					
CBB-150-AW-60K-D0L1	6000k	20190					
CBB-150-AW-50K-D0L1	5000k	20190	65-90~105°	SMD Ra > 80	150W	AW:100-240VAC 50-60Hz,Max1.8A	Angle Tunable
CBB-150-AW-40K-D0L1	4000k	19830					
CBB-150-AW-30K-D0L1	3000k	18480					
CBB-200-AW-60K-D0L1	6000k	27260					
CBB-200-AW-50K-D0L1	5000k	27260	65-90~105°	SMD Ra > 80	200W	AW:100-240VAC 50-60Hz,Max2.3A	140lm/W IP40
CBB-200-AW-40K-D0L1	4000k	26840					
CBB-200-AW-30K-D0L1	3000k	24810					
CBB-240-AW-60K-D0L1	6000k	32340					
CBB-240-AW-50K-D0L1	5000k	32340	65-90~105°	SMD Ra > 80	240W	AW:100-240VAC 50-60Hz,Max2.7A	
CBB-240-AW-40K-D0L1	4000k	32170					
CBB-240-AW-30K-D0L1	3000k	29850					
CBB-T120-AW-60K-D005	6000k						
CBB-T120-AW-50K-D005	5000k	9200~16000	105, 90, 60°	SMD Ra > 80	080~100~120W	AW:100-240VAC 50-60Hz,Max1.4A	
CBB-T120-AW-40K-D005	4000k						
CBB-T120-AW-30K-D005	3000k						
CBB-T150-AW-60K-D005	6000k						
CBB-T150-AW-50K-D005	5000k	9800~20190	105, 90, 60°	SMD Ra > 80	080~100~120~150W	AW:100-240VAC 50-60Hz,Max1.8A	Power Tunable
CBB-T150-AW-40K-D005	4000k						
CBB-T150-AW-30K-D005	3000k						
CBB-T200-AW-60K-D005	6000k						
CBB-T200-AW-50K-D005	5000k	12300~27260	105, 90, 60°	SMD Ra > 80	100~120~150~200W	AW:100-240VAC 50-60Hz,Max2.3A	
CBB-T200-AW-40K-D005	4000k						
CBB-T200-AW-30K-D005	3000k						

The list is the sample model, please refer to the model rules for details
 * "Y" maybe 0 TO 9, A TO Z.



- Power supply type** * 1: SOSEN-AW(Wide voltage) ; 3: SOSEN-HV(Ultrahigh voltage) ; 5: SOSEN-AW(Power Tunable)
- Angle** * 0: 105&120°; 1: 90°; 2: 60°; L: Angle Tunable
- Luminous efficiency** * 0: 140 lm/W level; 1: 160 lm/W level; A: 200 lm/W level
- Function** * D: Dimming; S: sensing & intelligent control; Blank: Nonfunctional
- CCT** * 30K(3000K); 35K(3500K); 40K(4000K); 50K(5000K); 60K(6000K); TCK:3000~4500~6000K
- Voltage** * AW: 100-240VAC; HV: 277-480VAC
- power** * 100W ; 120W ; 150W ; 200W ; 240W
- Category** * Cibay-B High Bay Light

Color matching and power adjustment settings

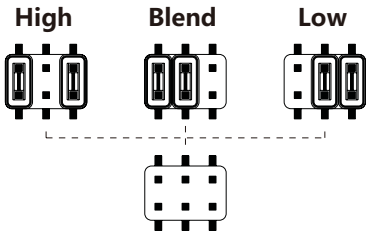

Open the cover of the sensor interface
 The CCT can be changed by switching the
 internal jumper cap position
 High:6000K
 Blend:4500K
 Low:3000K
 Risk of electric shock Please
 disconnect the power supply debugging

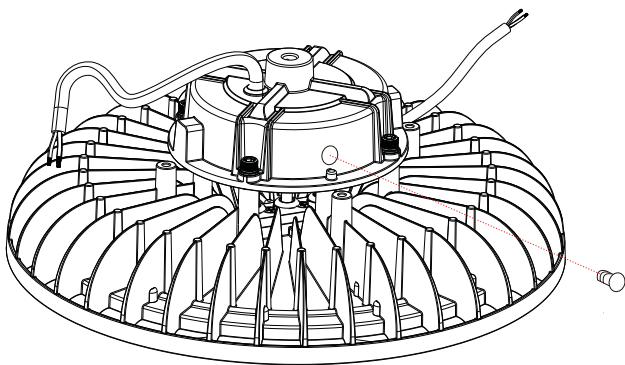

Pull out the silicone plug
 Set the power according to the right figure

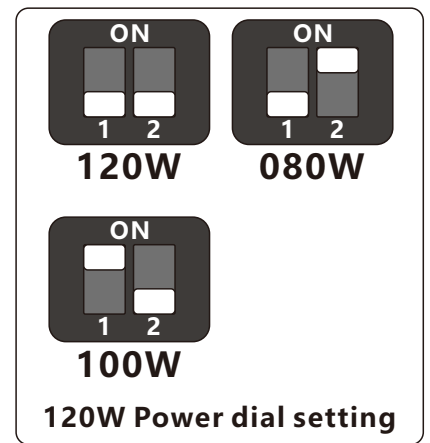
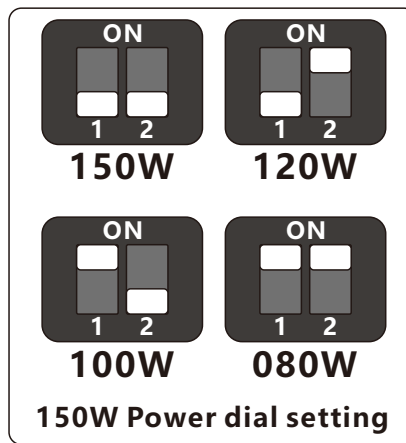
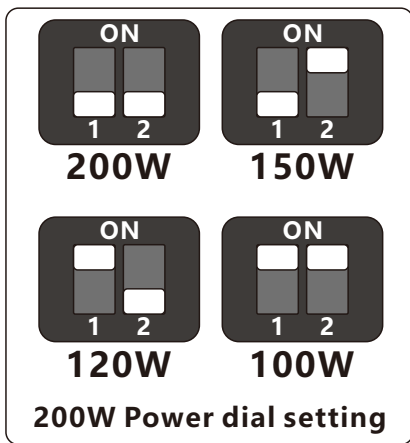

Distribution Diagram

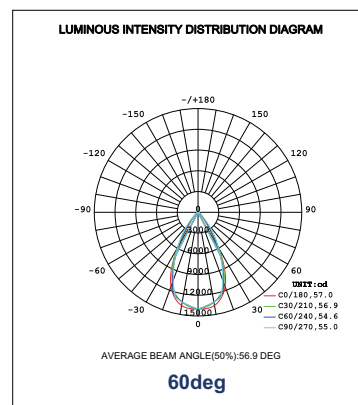
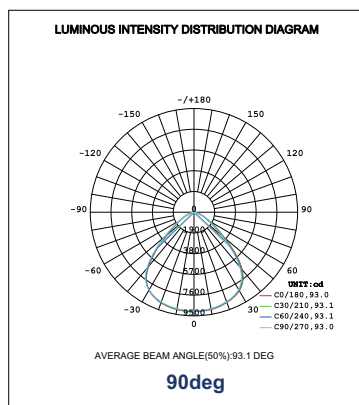
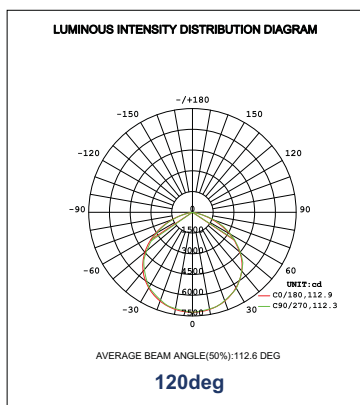

Dimension(Unit:mm/inch)

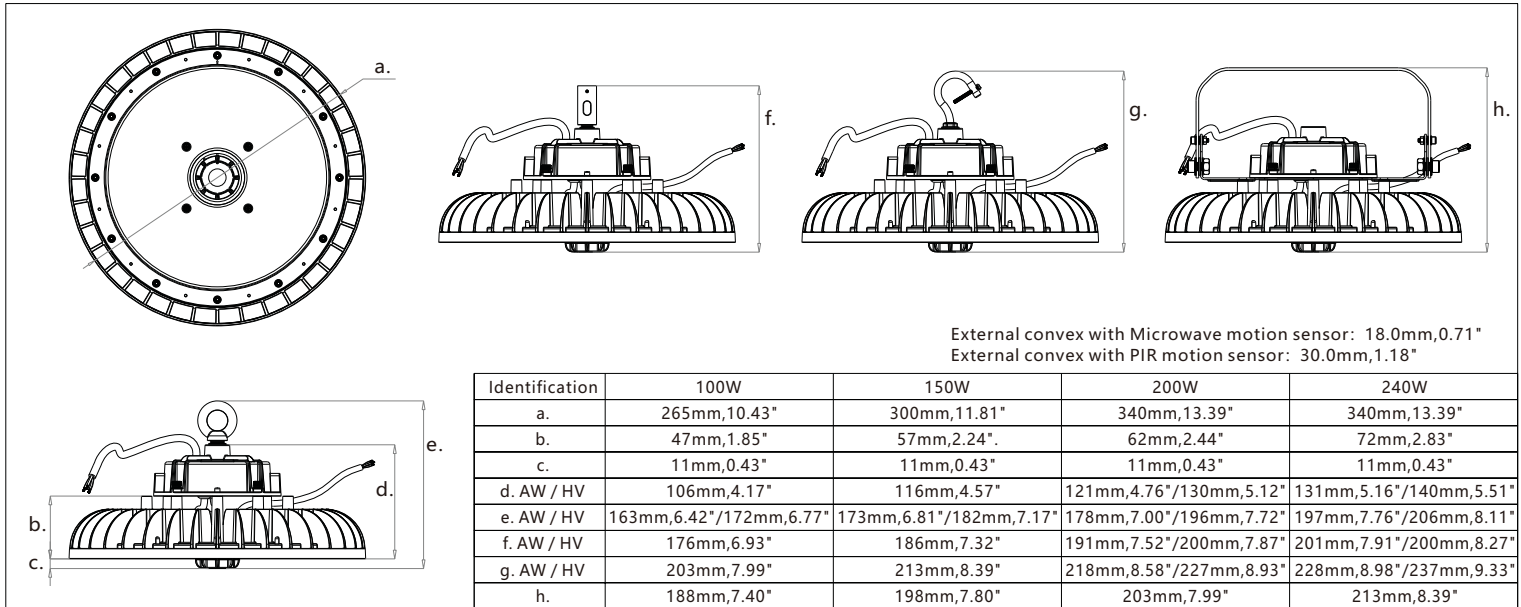

Package information

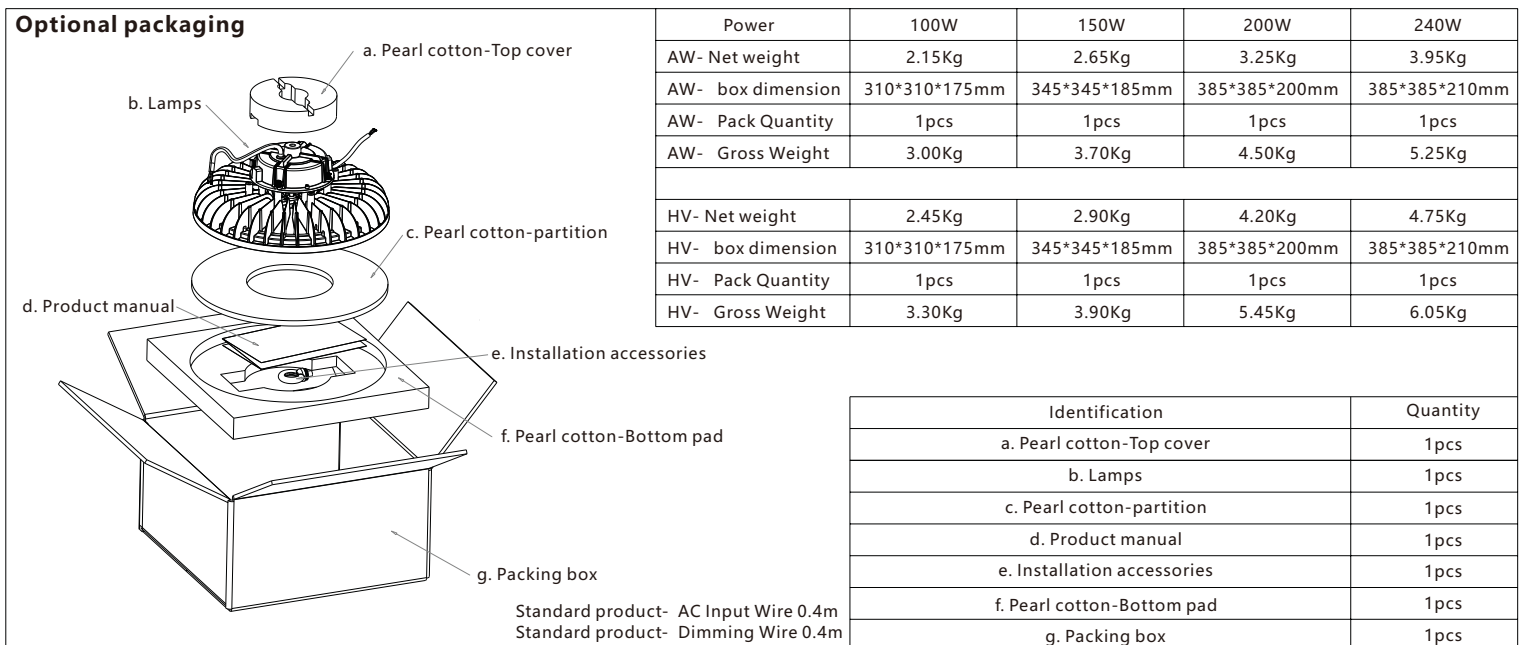
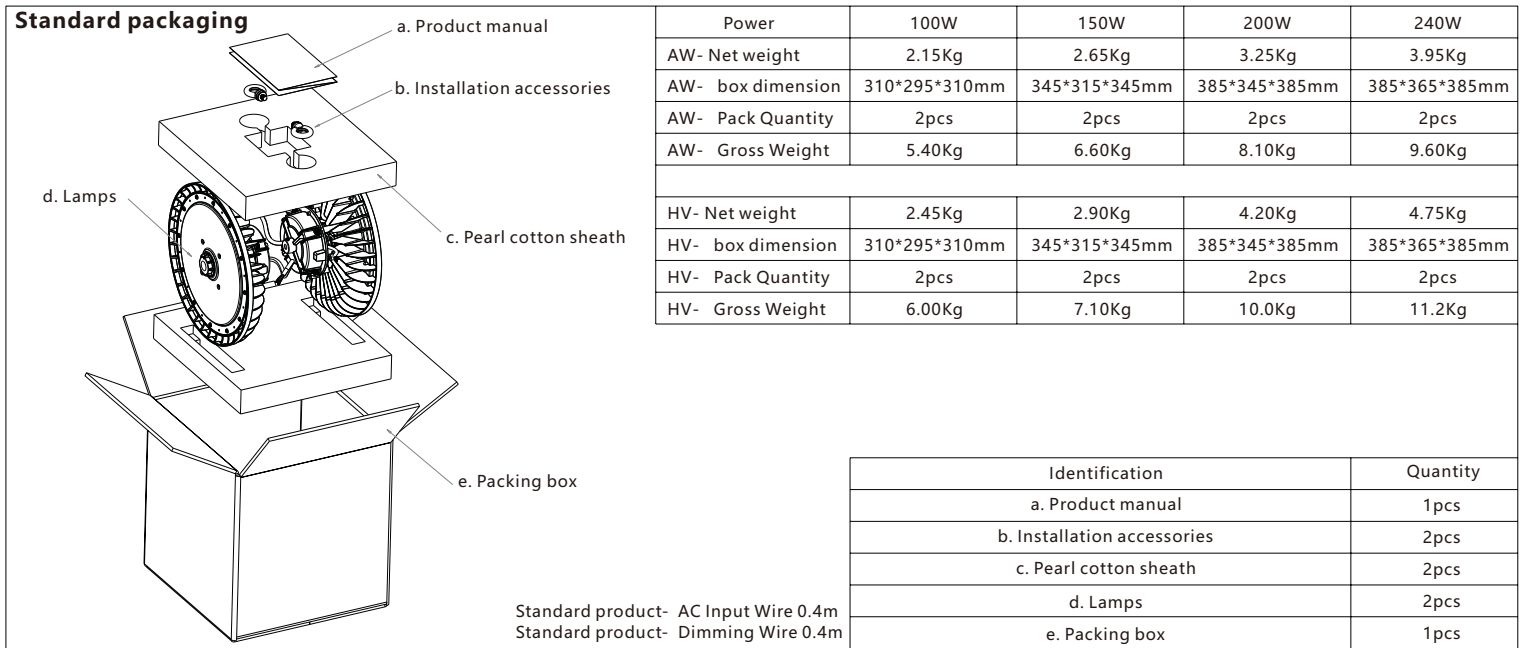

Product Installation

Suspension ring installation

The lifting ring is applicable to pendant with opening such as hook on the ceiling, climbing button carabiner as well as pendant carrier on which an opening may be made.

1. Screw the lifting ring into the interface on light top before installation.
2. Tighten the auxiliary anti-falling screws at side of the interface.
3. Make the hook on the ceiling thread through the lifting ring and hang the light stably.
4. If the pendant has lock catch or anti-off device, they should be at effective state.

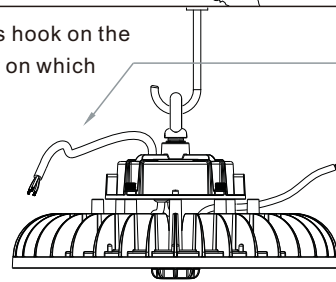

- AC INPUT
- L (brown/black wire)
 - GND (yellow & green/green wire)
 - N (blue/white wire)
- 1-10V dimming
- Dim-(white /gray wire)
 - V Aux (Black & white wire)
 - Dim+(blue/purple wire)

hook installation

Hook is applicable to be installed on sealed ring structure or pipes such as sealing hook, U-shaped circle hook, steel pipes or other carriers.

1. Screw the hook into the interface on light top before installation.
2. Tighten the auxiliary anti-off screws at side of the interface.
3. Loosen the sealing screws of the hook (the hook has an opening about 30mm).
4. Make the hook thread through the sealing ring and hang the light stably.
5. Tighten the sealing screws of the hook.

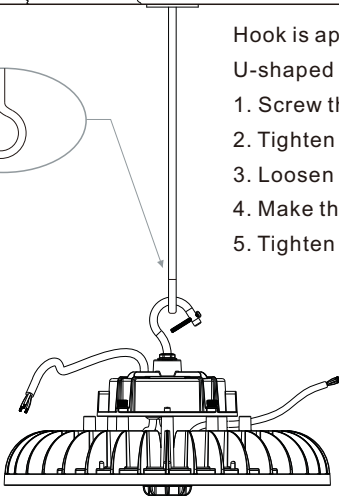

There are two types of adaptors for installation of corrugated pipe including 1/2NPT or 3/4NPT corrugated hose adaptors. As the installation mode of corrugated pipe is special, the supporting hose should meet the following characters :

- a. reach the bearing requirements no matter it is hard pipe or flexible pipes.
- b. The pipe opening has 1/2NPT or 3/4NPT threads.
- c. The thread length of pipe should be <25mm. It is suggested about 20mm.

1. Use M10 hexagon socket head cap screws to fix the adaptor at top interface of the light.
2. If the wire goes through the pipe, thread the cable into pipe cavity from side hole of the adaptor.
3. Tighten the auxiliary anti-off screws at side of the interface.
4. Perform spiral connection between the threaded pipes and adaptor.
5. Tighten the auxiliary anti-slide screws on the adaptor.

pipe installation

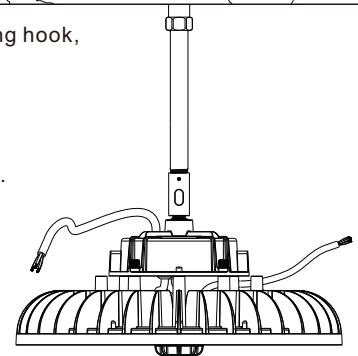

NPT Screwed pipe

U Bracket Ceiling or Wall Installation

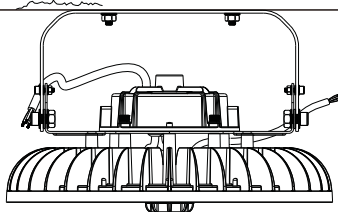

The U-shaped support is applicable to wall installation or ceiling installation. The installation position should comply with the bearing requirements. The following recommended size should be observed to open holes on the walls.

1. Insert the expansion screws into wall holes.
2. Make the head of expansion screws through installation hole of U-shaped support.
3. Tighten the expansion screws to make the support suck on the walls firmly.
4. Dismantle the auxiliary screws on two sides of the support and loose screws of the spindle slightly.
5. Rotate the support to suitable degree and replace auxiliary screws at two sides.

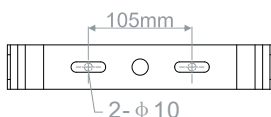

Recommended dimension of drilling hole

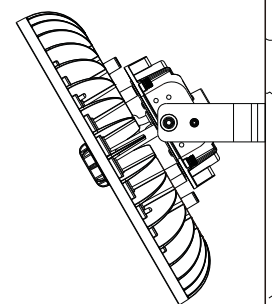

The power supply should be cut off during installation. If it is used in environment with vibration, the safety rope should be provided. In case of installation with lifting ring and hook, Can be extended by chain. Any installation mode should ensure that the carrier reaches effective bearing. The bearing capacity is four times or above of the total hung weight at least. The disconnection of power supply should be kept for 30 minutes at least for maintenance to prevent scalding by high heat.

Motion-sensing Function

These sensors provides multi-level control based on motion and/or daylight contribution, and all control parameters are adjustable via wireless configuration tool capable of storing.

Corridor Function

This function inside the motion sensor to achieve tri-level contro, for some areas which require a light change notice before switch-off. The sensor offers 3 levels of light: 100%dimmed light(natural light is insufficient)-->off; and 2 periods of selectable waiting time: motion hold-time and stand-by period; Selectable daylight threshold and freedom of detection area.



With sufficient natural light, the light does not switch on when presence is detected.

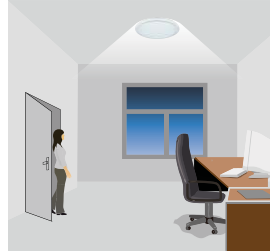

With insufficient natural light, the sensor switches on the light automatically when presence is detected.

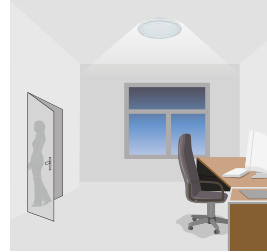

After hold-time, the light dims to stand-by level if the surrounding natural light is below the daylight threshold.



Light switches off automatically after the stand-by period elapses.

Note: if you choose STAND-BY DIM is 0, the stand-by period is 0, it is ON/OFF function

Smart Photocell Function

open the smart photocell sensor by push  when remote control is in setting condition



The light switches on at 100% when there is movement detected.

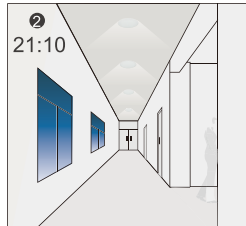

The light dims to stand-by level after the hold-time.

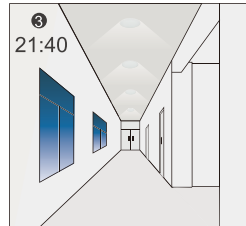

The light remains in dimming level at night.

Settings on this demonstration:

Hold-time: 10min

Setpoint on: 50lux

Setpoint off: 300lux

Stand-by Dim: 10%

Stand-by period: +∞

(when the smart photocell sensor open, the stand-by time is only +∞)

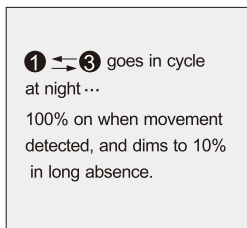

① ↔ ③ goes in cycle at night...
100% on when movement detected, and dims to 10% in long absence.

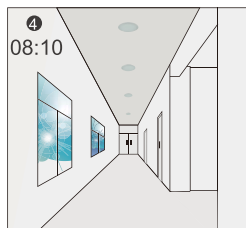

When the natural light level exceeds setpoint off to light, the light will turn off even if when the space is occupied.

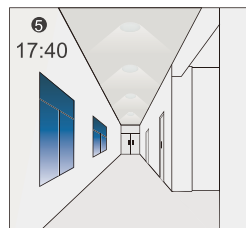

The light automatically turns on at 10% when natural light is insufficient (no motion).

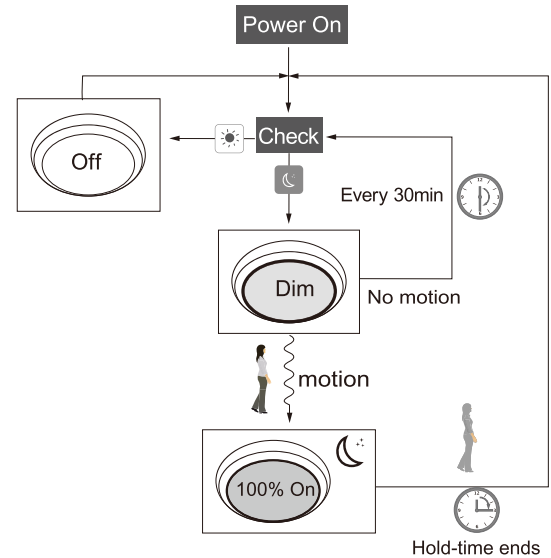

Difference between Corridor Function and Smart Photocell Function.

1. In corridor function, the daylight sensor as threshold to assist motion sensor, in Photocell function, the daylight sensor works independently to motion sensor.
2. Turn On light by detect motion when natural light is insufficient for corridor function, turn on light by natural light level exceeds setpoint on to light, do need to detect motion, for smart photocell function.
3. Turn off light by stand-by time for corridor function, Turn off light by natural light level lower than setpoint off of light for smart photocell function.

Technical parameter

Microwave motion sensor

Operating voltage	12V
Microwave frequency	5.8GHz
Transmitting power	<1mW
Mounting height	12m Max.
Detection radius	4m
Detection speed	0.5~1.5m/s

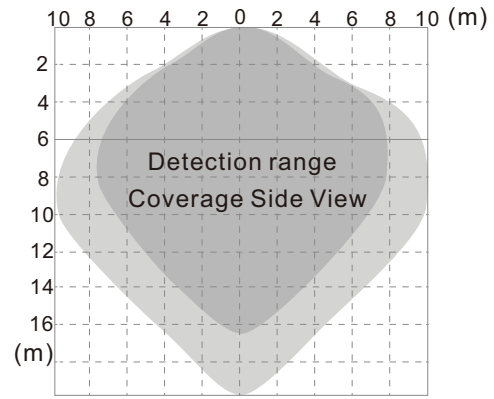

PIR motion sensor

Operating voltage	12V
Mounting height	Max 12m
Detection radius	4m
Detection speed	0.5~1.5m/s

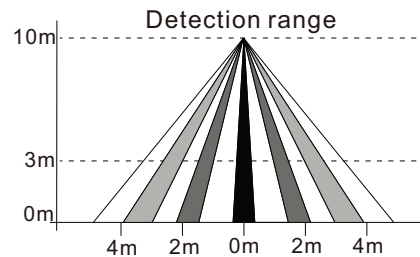

Difference description

It's commonly known Microwave and Infrared are main detecting technologies in lighting controls. Both have the advantage and disadvantage for industrial applications.

Advantage

- * sensitive to minor motion.
- * sensitive to radial movement.
- * can be reflected by objects hence covering big detection area
- * resilient to heat source, smoke and air conditioner.



Disadvantage

- * penetrates walls, picks up motions outside of the office area;
- * back wave detection, false trigger by motions at the back.
- * can be false triggered by ventilation fans, water pipe, elevators etc. in industrial application.



Microwave Motion Sensor

Advantage

- * no penetration, confined detection area.
- * sensitive to tangential movement.
- * resilient to motion object which has no heat radiation.



Disadvantage

- * can be false triggered by air conditioner, smoke and other heat sources.



PIR Motion Sensor

⚠ WARNING

Remove the batteries from compartment if the remote will not be used in 30 days.

SPECIFICATIONS

Power supply	2 x AAA 1.5V battery, Alkaline preferred
Carrying case	RC-100 in carrying case
Communication	940 nm Infrared Tx & Rx
Upload range	Up to 15 m (50 ft.)
Op. temperature	0°C~50°C (32°F~122°F)
Dimensions	123 x 70 x 20.3 mm (4.84" x 2.76" x 0.8")

OVERVIEW

The "RC100" Wireless IR Configuration Tool is a handheld tool for remote configuration of IR-enabled fixture integrated sensors. The tool enables device to modify via pushbutton without ladders or tools, and stores up to four sensor parameter modes to speed configuration of multiple sensors.

The "RC100" uses bidirectional IR communication to send and receive sensor settings at mounting height up to 50 feet. The device can display previously established sensor parameters, copy parameters and send new parameters or store parameter profiles. For projects where identical settings may be desired across a large number of areas or spaces, this capability provides a streamlined method of configuration. Settings can be copied throughout a site, or in different sites.

Sensor Remote Programmer

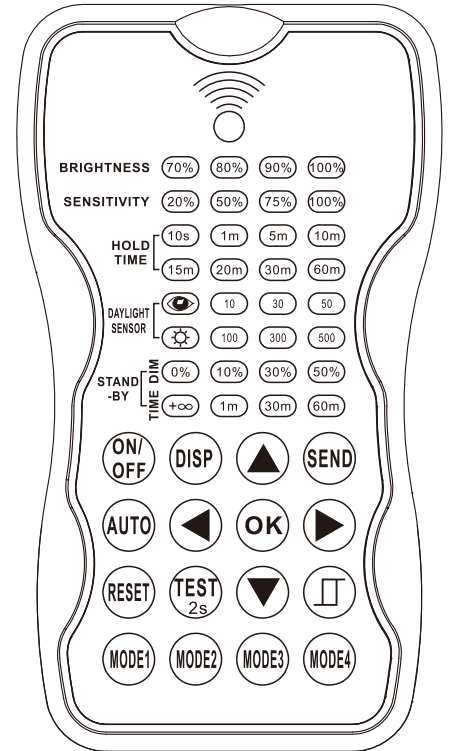







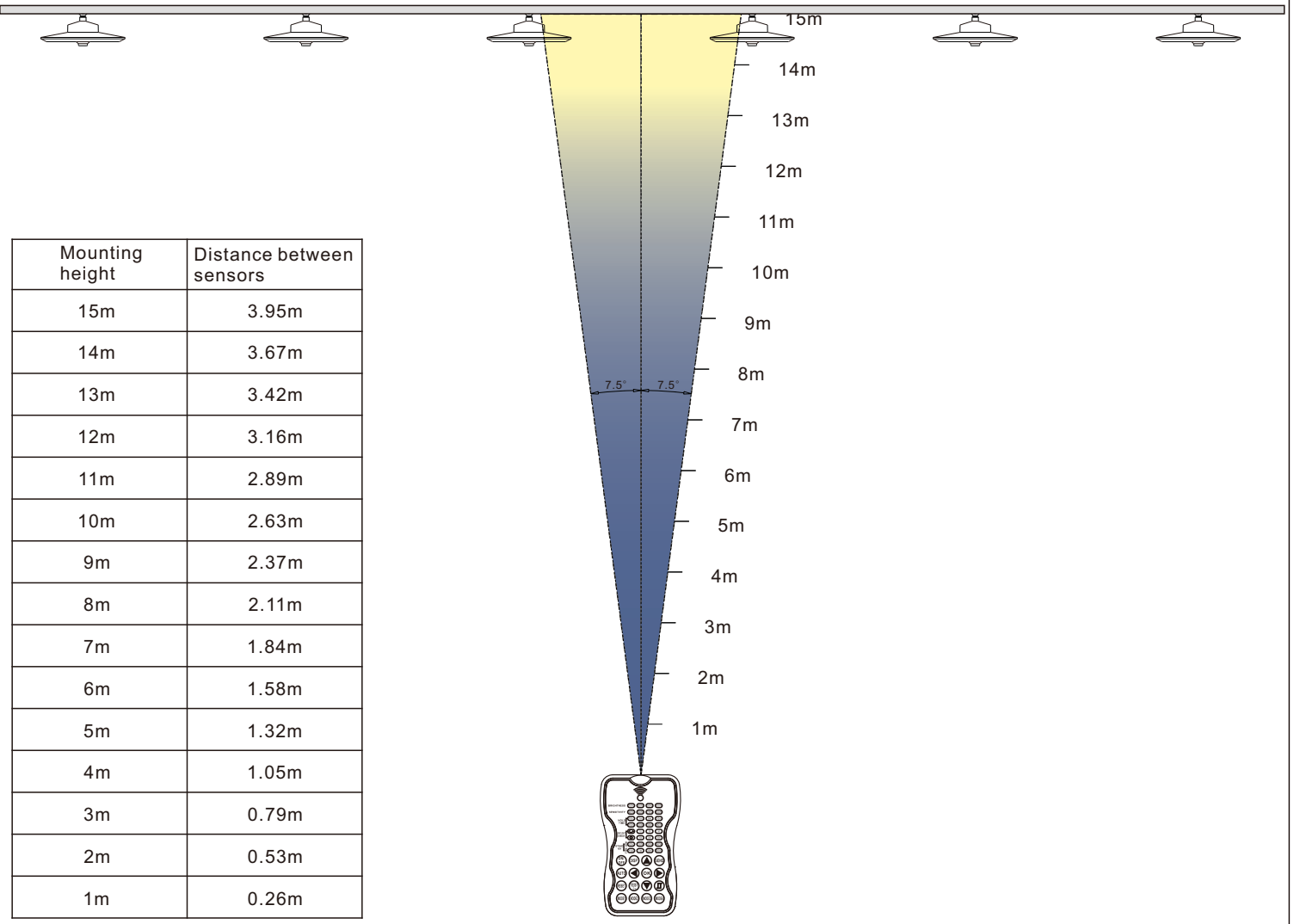

















As the control angle of the Infrared Remote Controller is fixed (15°),

If the distance between sensors is too close, the sensors in the signal range will be set at the same time Please refer to the below chart for the distance of the installation of the sensor. There may have slight deviations between dimension in the diagram and the real one!

Infrared remote control can not only transmit in a straight line, but also be reflected by objects., Different environments have different effects, The following is only for reference.



KEY DESCRIPTIONS

KEY	FUNCTION	KEY	FUNCTION
	Press the on/off button, the light goes to permanent on or permanent off mode, the sensor is locked, MUST Press "AUTO" to quit from this mode.		Press "Auto" button, the sensors start to work automatically and all parameters remain the same as the latest status in auto mode.
	Display current parameters		The button "Test" is for testing purpose sensitivity only. The sensor goes to test mode (hold time is only 2s) automatically after commissioning, meanwhile the stand-by period and daylight sensor are disabled. Press "AUTO" to quit from this mode.
	upload the selected parameters to sensors		
	Enter in the setting condition and navigate to UP and Down		When the light level exceeds this setting, the lights will turn off even when the space is occupied. Once the light level exceeds this setting, the sensor will wait and monitor for 1 min in order to confirm the light level increase is not temporary before forcing the lights to go off. When light level goes below the settings, the light will turn on even without motion detection after 1 min. This feature is disabled by default. If you want to open this setting, just press  , choose daylight sensor setpoint on/off.
	Navigate to Right and Left		
	Confirm selected parameters and saving		
	Default settings:      	 	Four modes with existing parameters which are available to be updated and saved in Modes
BRIGHTNESS	Adjust the light brightness during hold time.	 	
SENSITIVITY	Adjust sensor sensitivity	DAYLIGHT SENSOR	Select  / 10LUX/30LUX/50LUX /  threshold for sensor to turn light fixture ON. Select  , current surrounding lux value as daylight lux threshold, select  , the built-in daylight sensor stops working, and all motions detected could turn the light fixture on, no matter how bright the natural light is.
HOLD TIME	The time of light fixture remains at programmed 70%/80%/100% level after motion is not detected		
STAND-BY TIME	Select stand-by period at 1min/30min / 60min/+∞; Note: "+∞" means bi-level dimming control, fixture never switches off.	STAND-BY DIM	Select the stand-by dimming level at 0%/ 10%/30%/ 50%; Note: "0%" means on/off control;

NOTE:

The "RC100" is a universal remote programmer with ALL available settings and parameters for remote sensors. Some settings and parameters may not be available on specific type of sensor under certain control mode. Please refer to the installation instruction of the sensor for the available settings and control options.

COMMAND BUTTONS

THE COMMAND BUTTONS provides a quick selection of the following operations by pressing respective buttons.

- To turn on/off light manually, press "ON/OFF" button, the sensor is locked, MUST Press "AUTO" to quit from this mode.
- To test sensitivity only. Press "TEST" button, the sensor goes to test mode (hold time is only 2s) automatically after commissioning, meanwhile the stand-by period and daylight sensor are disabled. Press "AUTO" to quit from this mode.

- To send the current parameters to sensor ,aim to the sensor ,and press SEND button.

NOTE: any common button is pressed to sensor, the light will on one time and off as confirm.

SETTING

The SETTING Content contains all available settings and parameters for "RC-100" remote sensors. It allows you to change the available control, parameters, and operation of the sensor from factory default or current parameters.

NOTE:the setting works only in Auto mode.

Change multiple settings of sensor(s)

- 1.Press DISP button(if you push ON/OFF button before you push DISP button, the sensor is locked, so please push "AUTO" button to unlock the sensor ,and then push DISP button), the controller leds will show the latest parameters.
- 2.press ▲ or ▼ enter in the setting condition, navigate to the desired setting by pressing ▲▼◀▶ to select the new parameters.
- 3.press ok to confirm all setting and saving.
- 4.aim at the target sensor and press SEND to upload the new parameter. light will be one time and off , as confirm.

NOTE: 1.If you press DISP button, the remote control leds will show the latest parameters which were sent.

- 2.If you want to learn current surrounding lux value as daylight lux threshold, please choose 👁 when you select daylight sensor lux threshold.

Change multiple settings of sensor(s)(with daylight sensor on/off setpoint)

- 1.Press "DISP" , the remote control leds will show the latest parameters.
- 2.Press ▲▼◀▶ to Select the new parameter.
- 3.press ☐ ,daylight sensor off setpoint led in remote control will flash ,select daylight sensor setpoint for turn light off,and select daylight sensor setpoint for turn the light on .
- 4.press ok to confirm all setting and saving.
- 5.aim at the target sensor and press "SEND" to upload the new parameter.light will be one time and off , as confirm.

NOTE: ☐ is disabled by default.

- 1.Open or close daylight sensor on/off setpoint, it only works when remote control in the setting condition, you just push ☐ , daylight sensor setpoint on/off setpoint will be close or open.
- 2-1.when daylight sensor works, the setpoint on lux must be 10lux,30lux,50lux,not 👁 , the light turn on when natural light lower than 10lux,30lux,50lux even without motion detection after 1min.
- 2-2:when daylight sensor works, the setpoint off lux must be 100lux,300lux,500lux,not ⚙ , the light turn off when natural light exceeds than 100lux,300lux,500lux even with motion detection after 1min.
- 2-3: when daylight sensor works,the stand-by time is only +∞ .
3. ☐ is normal for outdoor using,not for indoor .

About RESET and MODE(1,2,3,4)

The "RC-100" comes with four MODES which are not default. You may make desired parameters and save as a new MODE(1,2,3,4) to configure the installed sensors.

RESET:

MODE	BRIGHTNESS	SENSITIVITY	HOLD TIME	DAYLIGHT SENSOR	STAND-BY DIM	STAND-BY TIME
MODE1	100%	75%	5min		30%	30min
MODE 2	100%	75%	1min		30%	+∞
MODE 3	100%	75%	5min	30Lux	30%	30min
MODE 4	100%	75%	1min	30Lux 300Lux	30%	+∞

Make a new Mode :

- 1.press / / / button, the remote control leds show existing parameters.
- 2.press to select the new parameters.
- 3.if want to open/close daylight sensor lux setpoint on/off , press ,select right lux setpoint.
- 4.Press "OK" to confirm all parameters and saving in the mode.

NOTE: if do not know existing parameters in / / / , repeat Step 1.

UPLOAD

The upload function allows you to configure the sensor with all parameters in one operation. You may select CURRENT SETTING parameters or the MODE for uploading. Current setting parameters or the MODE are displayed in "RC-100" Remote control .

Upload the current parameters to sensor(s),and duplicate the sensor parameters form one to anther

- 1.Press Display button OR press / / / , all parameters are displayed in "RC100" Remote control.

Note: check if all parameters are correct , if not, change them.

- 2.Aim at the sensor and press "SEND" button , the light will be one time on and off , as confirm.

Note: if other sensors need same parameters, just aim at the sensor and press "SEND" button.

Installation requirements

1. Disconnect power supply, and read product instructions carefully;
2. Ensure installation accessories and installation environment conform to bearing requirement;
3. Check whether the installation accessories are damaged or not, and install accessories to lamp reliably;
4. Different installation environment match corresponding installation accessories, do not use or change at will;
5. If the installation fittings has auxiliary parts such as skidproof screw, notice how it works, please do not ignore it;
6. If the light is installed in vibration environment, please add anti-falling safety rope to ensure reliability of installation;
7. Connect power supply wire reliably according to specified polarity; I-type lamp with grounding line shall be earthed reliably and the connection points must have insulation measures;
8. When the installation is completed, check whether all parts is reliable and can work properly.

Notice

1. Please first read the product specification carefully, make sure the using environment conform to specification, then it can be used;
2. Please confirm the input voltage and frequency before use;
3. This product must be installed by professionals;
4. If there is any damage to the power wire or shell of the product, it shall be taken as defective product and do not use it;
5. Dangerous high voltage, non-professionals are not allowed to maintain the product;
6. If external soft cable or soft wire of the light is damaged, it shall be replaced by manufacturer or service agent or personnel with similar qualification to avoid danger;
7. Corrosivity in the using environment can't exceed the specified anti-corrosion grade, if you have special requirement, please first consult with our company.