

LED Slim Downlight

-CCT adjustable Version 1

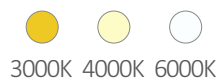

Color temperature adjustable





Application

Suitable for shop, supermarket, shopping mall, hospital, office, house, shopping mall, factory and other indoor places.

Features

- Super slim lamp body, 16.8mm high;
- The diffuser plate adopt double-sided frosted plate, more uniform light;
- The frame adopt ADC 12, better cooling effect; adopt low-power large LEDs, and LEDs work in low temperature;
- The back cover adopt bending, powder spraying; consistent whole effect, and prevent light-leaking;
- The driver is designed with high PF(PF>0.9) and fliceker-free.
- The lamp protection degree is IP44 , so the lamp can be used in bathroom, kitchen and other wet location.
- The lamp is designed with low SDCM(SDCM<3)

The Design for Lamp

- Great spring elasticity, **6N-8N** force.
- Waterproof ring for use in **wet location**.

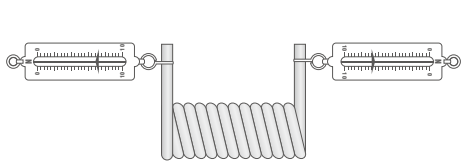

- Super slim lamp body **16.8 mm** thickness, applicable for any ceiling.

- Acrylic light guide, laser dotting, **no yellowing**, long life span.

- Adopt edge-lit tech, visual uniformity, **CRI option 80 or 90**.

- Connector with strain relief design.



- Fashionable, concise junction box design.

- The Cable is High fire rating FT1, temperature resistance up to 105°C.

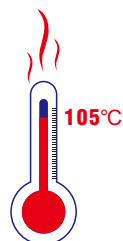

Specifications

| Model | Color | CCT | Luminous flux (-10%) | Power (W) | Cutout size | Beam angle | Input Voltage | LED type | CRI | IP | PF |
|------------------------|------------------|-------------------|----------------------|-----------|-------------|------------|---------------|----------|-----|------|-------|
| SC-DL09-D145-R-AW-01RE | 3 CCT adjustable | 3000K-4000K-6000K | 550 | 9W | 135mm | 110° | 220-240VAC | 2835 | 80 | IP44 | > 0.9 |
| SC-DL12-D180-R-AW-01RE | | | 880 | 12W | 170mm | | | | | | |
| SC-DL18-D220-R-AW-01RE | | | 1500 | 18W | 205mm | | | | | | |
| SC-DL22-D220-R-AW-01RE | | | 1800 | 22W | 205mm | | | | | | |

Dimensions (unit:mm)

4 inch

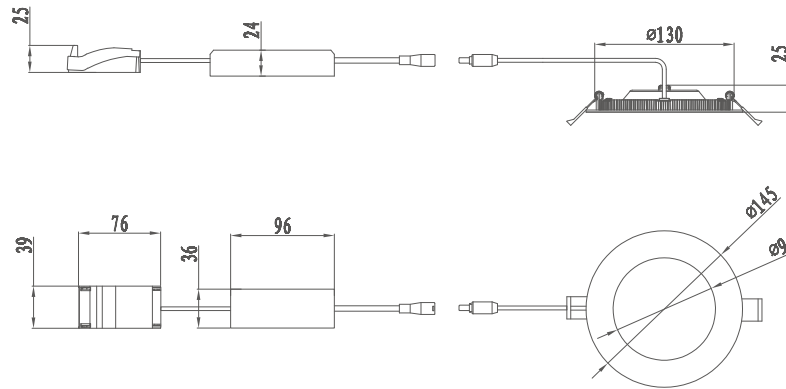

6 inch

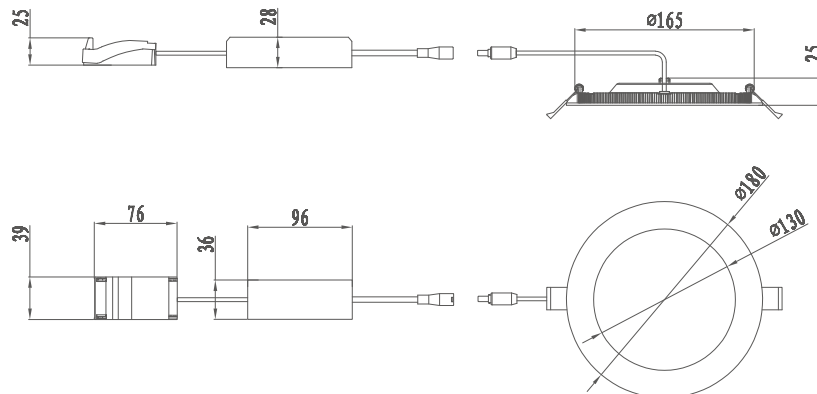

8 inch

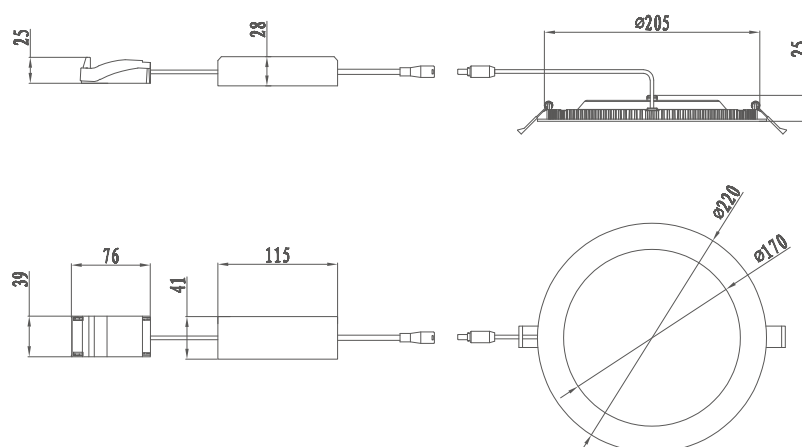

Installation drawing

LED round panel light can perfect replace traditional down light, Low light pollution, excellent protection from eyestrain.

1. Drill hole according model

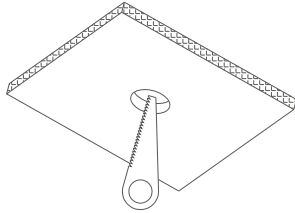

Note: Please check the hole size at model list table

2. Before installation, please slide the dip switch to the right color temperature at the driver box.

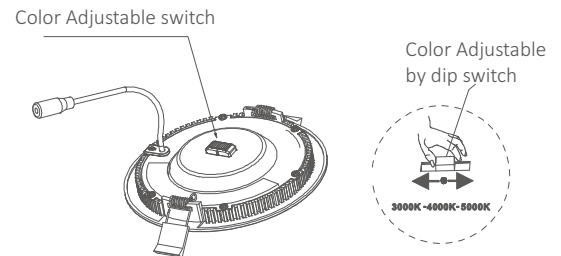

3. Rotate right-handed with slotted screwdriver to remove the top cover. Open the side knockout of the junction box with slotted screwdriver.

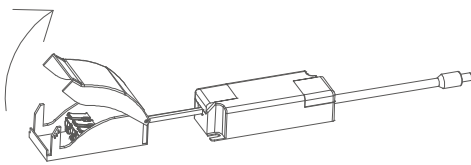

4. Blue wire is connected to N; Brown wire is connected to L; and yellow-green wire is connected to G.

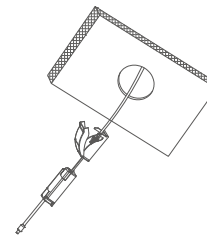

5. Embed the light into the hole of ceiling.

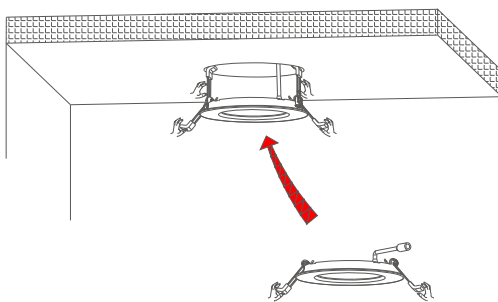

Installation requirements

- Power off before installation;
- Drill proper hole into the ceiling according to product model;
- Connect AC wire;
- Embed the light into ceiling hole;
- Light up and test, installation finish.

Packaging information

| Information \ Size | 4 Inch Round | 6 Inch Round | 8 Inch Round |
|--------------------|-------------------------------|-------------------------------|-------------------------------|
| Net weight/CTN | 0.28Kg | 0.36Kg | 0.55Kg |
| Gross weight/CTN | 16.3Kg | 20.5Kg | 14.6Kg |
| Inner size/mm | 220x185x55 | 250x225x55 | 305x265x55 |
| Carton size/mm | 520x390x460 | 540x520x456 | 556x520x325 |
| | 1pcs/inner box, 40 pcs/carton | 1pcs/inner box, 40 pcs/carton | 1pcs/inner box, 20 pcs/carton |

Notice



- Please read the specification first, to make sure the service environment matches the condition in the specification before using.
- Please confirm the applicable power supply before using.
- Make sure the switch of product is off before connect to the power supply to prevent electric shock.
- Operation against rules may damage your property even harm to your personal safety.
- Preliminarily estimate required quantity of LED panel lights, then according to the power rating of single panel light to figure out the total power and design power supply plan.
- Dangerous high voltage, Non-professionals are not allowed to maintain the products.
- If the exterior flexible cable or wire is damaged, it must exchange by the supplier, its agent or other similar qualified personnels to avoid dangers.



Yijia Industrial Park, Fuqian Road, Guanlan Town, LongHua, Shenzhen, Guangdong, China

Tel:+86-755-27608650
 Fax:+86-755-27608651
www.signcomplex.com
sales@signcomplex.com